

## Calibrating voltage input signal conditioners using the Fluke 787 ProcessMeter™

### Application Note

Many manufacturing and processing plants carry a wide variety of signal conditioning devices. The Fluke 787 ProcessMeter is an ideal tool for calibrating many 4-20 mA signal conditioners using its precision current sourcing and simulation capabilities. However, there are many signal conditioners that require a precision voltage source for proper calibration. Using a simple precision resistor and standard connector, the Fluke 787 can field calibrate many standard and non-standard voltage input signal conditioners.

Voltage input signal conditioners come in many varieties. The most common are 0-10 V and 0-5 V input levels. Typical outputs of these devices are an isolated or non-isolated 0-10 V or 4-20 mA. Signal conditioners with inputs of 1-5 V or 2-10 V are also prevalent in many applications and usually derive their inputs from a resistor in series with a 4-20 mA loop. Resistors with values of 250  $\Omega$  to 500  $\Omega$  are common loop load resistors and provide voltage input levels as a function of the loop current. (See Figure 1.)

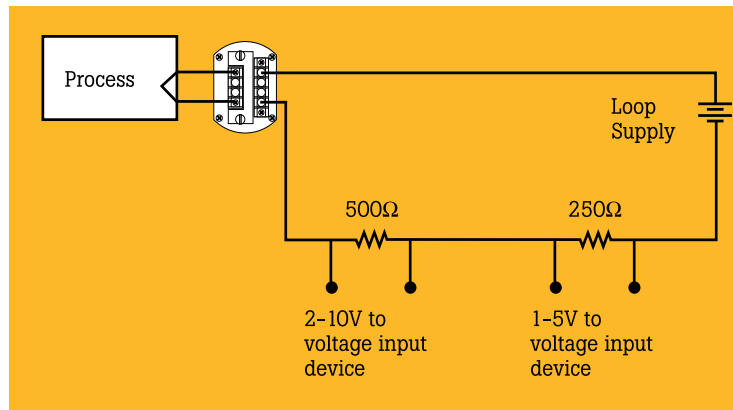

Figure 1.

### Using the Fluke 787 ProcessMeter as a voltage source

A hand-selected, precision shunt resistor may be used to derive voltages for calibration using the Fluke 787's current source mode.

Using this system, the Fluke 787 is capable of generating voltages for devices with input spans as low as 10 mV to as high as 12 V.

Table 1 gives values of precision resistors to accommodate a variety of voltage calibrations.

Resistor Value	Sourced Current	Fluke 787 Display	Sourced Voltage
10 $\Omega$	0-20 mA	0-20.000	0-200.00 mV
100 $\Omega$	0-20 mA	0-20.000	0-2.000 V
1000 $\Omega$	0-12 mA	0-12.000 mA	0-12.000 V

Table 1. Values of precision resistors to accommodate a variety of voltage calibrations

Note: Input impedance of the device under test should be  $\geq 1$  M $\Omega$

### Constructing a precision load resistor assembly

A simple precision current shunt can be constructed using a precision 1000 Ω, RN60, 1 W resistor, a dual banana jack connector and some test leads with alligator clips (see Figure 2). The RN60 class resistor is available from many commercial sources. This resistor can be obtained in a 50 ppm/°C, 0.1 % value which provides the stability and accuracy sufficient for most field calibrations. The resistor should be hand selected using a precision DMM for a value of 1000 Ω. Construct the assembly as shown in Figure 2. This precision resistor assembly, coupled with the precision current sourcing capabilities of the Fluke 787, will provide precision voltages up to 12 V. This assembly will allow a direct one-to-one display correlation to voltage when sourcing current from the Fluke 787 during calibration.

### Calibrating the signal conditioner

The following is a procedure for calibrating a 0-10 V input, 4-20 mA output signal conditioner using the precision resistor assembly constructed in Figure 2.

#### Step one

##### Setting the Fluke 787 to source 0-20 mA

1. With the shunt assembly in the "source" jacks, turn the meter to **OUTPUT** .  

2. Check the display. If the display does not read 0 mA, turn the meter off and on again while holding the **RANGE** button for at least two seconds. The display should now read 0.000 mA.

#### Step two

##### Calibrating

1. Place a precision multimeter such as the Fluke 87, set to dc current mode, in series with the output of the signal conditioner as shown in Figure 3.
2. Connect the test leads from the precision shunt assembly to the signal conditioner input terminals, observing proper polarity.
3. Turn the Fluke 787 to the mA source setting. The display should read 0.000 mA (0.000 V to the shunt).
4. Adjust the "Zero" control on the signal conditioner to display 4.000 mA on the multimeter connected to the signal conditioner's output.
5. Press the **MIN MAX** button on the Fluke 787 four times until the display reads 20.000 mA. Then adjust the span adjustment on the signal conditioner until the display on the output meter reads 20.000 mA.
6. Push the **)))** button four times until the display on the Fluke 787 reads 0.000. Verify the meter connected to the output signal conditioner reads 4.000 mA.
7. **Calibration is now complete.**

*Note: Many manufacturers specify a warm-up time prior to beginning calibration.*

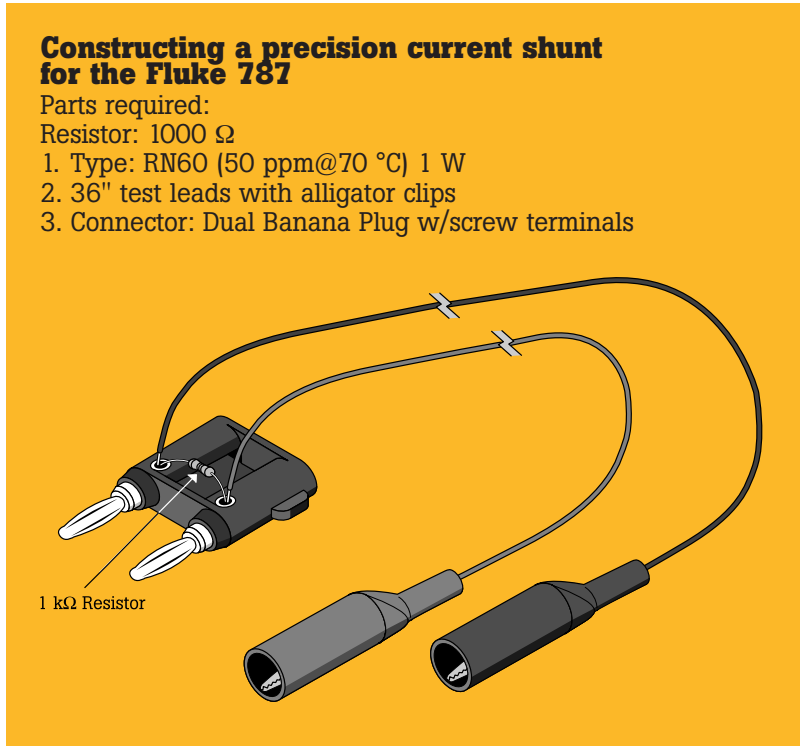

Figure 2.

### Step three

#### Checking linearity

Once zero and span controls have been properly set, signal conditioner linearity may be verified using the following procedure. This procedure will check Zero, 25 %, 50 %, 75 % and Span settings for signal conditioner linearity.

1. With the precision resistor assembly in place, adjust the source current of the Fluke 787 to 0 mA (0.0 V) using the "min-max" or "Sound" button. Note the measured output meter value is 4 mA.
2. Using the min-max button, step the source current to 25 %, 50 %, and 100 % and note the corresponding values. Table 2 shows the correct values of output for a linear signal conditioner. (If values differ from that shown in Table 2 by more than the linearity specification of the signal conditioner, contact the signal conditioner manufacturer.)

The Fluke 787 ProcessMeter™ is the first integrated multimeter and loop calibrator designed with the needs of the process professional in mind.

Fluke 787 Display Reading	% Input	Input Voltage	Output Current
0.000	0	0V	4.000 mA
2.500	25	2.500 V	8.000 mA
5.000	50	5.000 V	12.000 mA
7.500	75	7.500 V	16.000 mA
10.000	100	10.000 V	20.000 mA

Table 2. Correct values of output for a linear signal conditioner.

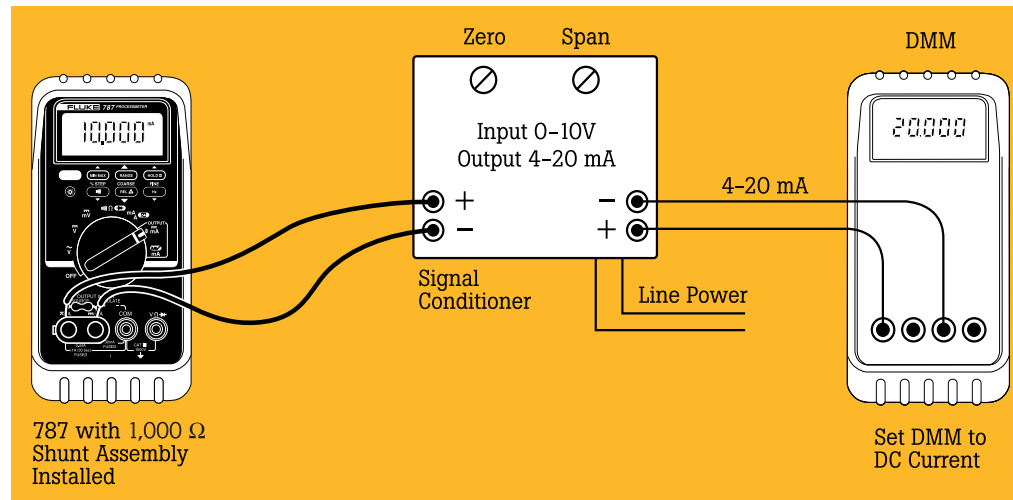

Figure 3.

## Making Fine Adjustments (dealing with interactive control adjustments)

Many signal conditioners with 0-20 mA and 4-20 mA outputs are notorious for zero and span control interaction. If, when performing step 6 in the calibrating section on page 2, your output meter displayed a value higher or lower than 4 mA, perform the following steps to effect the required 4 and 20 mA display on the output meter.

1. Note the value above or below 4 mA that was displayed on the output meter when you returned to a source value of 0.000 on the Fluke 787. Adjust the Zero control on the signal conditioner so the value of the output meter shows one-half the difference of the remaining mA value to 4 mA.  
Example: If your display reading at zero input in step 7 was 3.50 mA. Adjust the output (with 0.000 source current) to display a reading of 3.75 which is one-half the delta toward the desired value of 4 mA.

(eg.  $4.00 - 3.50 = 0.50$ ;  $0.05 / 2 + 3.50 = 3.75$ , or one-half the difference between the reading and the desired value.)

2. Set the source current of the Fluke 787 to 20.000 using the (min-max) button. Note the "output" meter display reading. Adjust the "Span" control of the signal conditioner one-half the delta from 20 mA.  
Example: If the output display reads 21 mA. Adjust the Span control to 20.5 mA. (One-half the delta to the required value of 20 mA.)
3. Repeat this "one-half step" process until the required output is obtained. (The interactions of Zero and Span controls on signal conditioners that exhibit this trait diminishes as the deltas become less.) There are signal conditioners that have non-interactive controls which do not require this procedure.

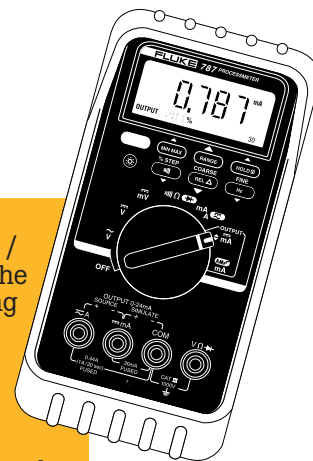

**Fluke.** Keeping your world up and running.

**Fluke Corporation**  
 PO Box 9090, Everett, WA USA 98206  
 Fluke Europe B.V.  
 PO Box 1186, 5602 BD  
 Eindhoven, The Netherlands  
 For more information call:  
 In the U.S.A. (800) 443-5853 or  
 Fax (425) 446-5116  
 In Europe/M-East/Africa (31 40) 2 675 200 or  
 Fax (31 40) 2 675 222  
 In Canada (800) 36-FLUKE or  
 Fax (905) 890-6866  
 From other countries +1 (425) 446-5500 or  
 Fax +1 (425) 446-5116  
 Web access: <http://www.fluke.com>

©2003 Fluke Corporation. All rights reserved.  
 Printed in U.S.A. 9/2003 1264324 A-ENG-N Rev B