

1662/1663/1664 FC

Electrical Installation Tester

Calibration Manual

LIMITED WARRANTY AND LIMITATION OF LIABILITY

Each Fluke product is warranted to be free from defects in material and workmanship under normal use and service. The warranty period is three years and begins on the date of shipment. Parts, product repairs, and services are warranted for 90 days. This warranty extends only to the original buyer or end-user customer of a Fluke authorized reseller, and does not apply to fuses, disposable batteries, or to any product which, in Fluke's opinion, has been misused, altered, neglected, contaminated, or damaged by accident or abnormal conditions of operation or handling. Fluke warrants that software will operate substantially in accordance with its functional specifications for 90 days and that it has been properly recorded on non-defective media. Fluke does not warrant that software will be error free or operate without interruption.

Fluke authorized resellers shall extend this warranty on new and unused products to end-user customers only but have no authority to extend a greater or different warranty on behalf of Fluke. Warranty support is available only if product is purchased through a Fluke authorized sales outlet or Buyer has paid the applicable international price. Fluke reserves the right to invoice Buyer for importation costs of repair/replacement parts when product purchased in one country is submitted for repair in another country.

Fluke's warranty obligation is limited, at Fluke's option, to refund of the purchase price, free of charge repair, or replacement of a defective product which is returned to a Fluke authorized service center within the warranty period.

To obtain warranty service, contact your nearest Fluke authorized service center to obtain return authorization information, then send the product to that service center, with a description of the difficulty, postage and insurance prepaid (FOB Destination). Fluke assumes no risk for damage in transit. Following warranty repair, the product will be returned to Buyer, transportation prepaid (FOB Destination). If Fluke determines that failure was caused by neglect, misuse, contamination, alteration, accident, or abnormal condition of operation or handling, including overvoltage failures caused by use outside the product's specified rating, or normal wear and tear of mechanical components, Fluke will provide an estimate of repair costs and obtain authorization before commencing the work. Following repair, the product will be returned to the Buyer transportation prepaid and the Buyer will be billed for the repair and return transportation charges (FOB Shipping Point).

THIS WARRANTY IS BUYER'S SOLE AND EXCLUSIVE REMEDY AND IS IN LIEU OF ALL OTHER WARRANTIES, EXPRESS OR IMPLIED, INCLUDING BUT NOT LIMITED TO ANY IMPLIED WARRANTY OF MERCHANTABILITY OR FITNESS FOR A PARTICULAR PURPOSE. FLUKE SHALL NOT BE LIABLE FOR ANY SPECIAL, INDIRECT, INCIDENTAL OR CONSEQUENTIAL DAMAGES OR LOSSES, INCLUDING LOSS OF DATA, ARISING FROM ANY CAUSE OR THEORY.

Since some countries or states do not allow limitation of the term of an implied warranty, or exclusion or limitation of incidental or consequential damages, the limitations and exclusions of this warranty may not apply to every buyer. If any provision of this Warranty is held invalid or unenforceable by a court or other decision-maker of competent jurisdiction, such holding will not affect the validity or enforceability of any other provision..

Fluke Corporation
P.O. Box 9090
Everett, WA 98206-9090
U.S.A.

Fluke Europe B.V.
P.O. Box 1186
5602 BD Eindhoven
The Netherlands

Table of Contents

Title	Page
Introduction	1
How to Contact Fluke	1
Safety Information	2
Specifications	4
Maximum Display Values	5
Electrical Measurement Specifications	8
Operating Ranges and Uncertainties per EN 61557	14
Operating Uncertainties per EN 61557	15
Required Equipment	16
Basic Maintenance	16
Clean the Tester	16
Test and Replace Batteries	16
Fuse Test	17
Performance Tests	18
Backlight Test	18
LCD Test	18
IR Port Verification	19
Touch Pad Sense Test	19
Memory Mode Test	20
Battery Gauge Test	21
Accuracy Tests	21
Volt and Insulation Functions	21
Continuity Function	24
LOOP ZI NO TRIP, L-PE	27
Loop ZI Hi Current	29
RCD Trip Current	31
RCD Trip Time	32
Earth Resistance (1663/1664 FC)	33
Accessories and Replaceable Parts	34

Introduction

The Fluke 1662/1663/1664 FC Series (the Tester or Product) are battery-powered electrical installation testers. This manual applies to all 1662, 1663, and 1664 FC models. All figures show the Model 1664 FC.

⚠⚠ Warning

To prevent electric shock or personal injury, do not perform the calibration verification tests or calibration procedures described in this manual unless you are qualified to do so. The information provided in this manual is for the use of qualified personnel only.

This manual provides all the information necessary to perform basic maintenance and make calibration adjustments.

For complete operating instructions, refer to the *1662/1663/1664 FC Installation Testers Users Manual* at www.fluke.com.

How to Contact Fluke

To contact Fluke, call one of the following telephone numbers:

- Technical Support USA: 1-800-44-FLUKE (1-800-443-5853)
- Calibration/Repair USA: 1-888-99-FLUKE (1-888-993-5853)
- Canada: 1-800-36-FLUKE (1-800-363-5853)
- Europe: +31 402-675-200
- Japan: +81-3-6714-3114
- Singapore: +65-6799-5566
- Anywhere in the world: +1-425-446-5500

Or, visit Fluke's website at www.fluke.com.

To register your product, visit <http://register.fluke.com>.

To view, print, or download the latest manual supplement, visit <http://us.fluke.com/usen/support/manuals>.

Safety Information

A **Warning** identifies hazardous conditions and procedures that are dangerous to the user. A **Caution** identifies conditions and procedures that can cause damage to the Product or the equipment under test.

Warning













To prevent possible electrical shock, fire, or personal injury:

- Use the Product only as specified, or the protection supplied by the Product can be compromised.
- Carefully read all instructions.
- Read all safety information before you use the Product.
- Do not use the Product around explosive gas, vapor, or in damp or wet environments.
- Comply with local and national safety codes. Use personal protective equipment (approved rubber gloves, face protection, and flame-resistant clothes) to prevent shock and arc blast injury where hazardous live conductors are exposed.
- Do not use the Product in distribution systems with voltages >550 V.
- Do not touch voltages >30 V ac rms, 42 V ac peak, or 60 V dc.
- Do not use test leads if they are damaged. Examine the test leads for damaged insulation and measure a known voltage.
- Do not apply more than the rated voltage between the terminals or between each terminal and earth ground.
- Do not apply more than the rated voltage between the terminals or between each terminal and earth ground.
- Measure a known voltage first to make sure that the Product operates correctly.
- The battery door must be closed and locked before you operate the Product.
- Examine the case before you use the Product. Look for cracks or missing plastic. Carefully look at the insulation around the terminals.
- Use the correct terminals, function, and range for measurements.
- Use Product-approved measurement category (CAT), voltage, and amperage rated accessories (probes, test leads, and adapters) for all measurements.
- Do not exceed the Measurement Category (CAT) rating of the lowest rated individual component of a Product, probe, or accessory.
- Do not use in CAT III or CAT IV environments without the protective cap installed. The protective cap decreases the possibility of arc flash caused by short circuits.
- Keep fingers behind the finger guards on the probes.
- Replace the batteries when the low battery indicator shows to prevent incorrect measurements.
- Remove all probes, test leads, and accessories before the battery door is opened.
- Be sure that the battery polarity is correct to prevent battery leakage.
- Repair the Product before use if the battery leaks.
- Have an approved technician repair the Product.
- Use only specified replacement parts.
- Replace a blown fuse with exact replacement only for continued protection against arc flash.

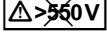
- **Do not operate the Product with covers removed or the case open. Hazardous voltage exposure is possible.**
- **Disable the Product if it is damaged.**
- **Do not use the Product if it is damaged.**
- **Remove the input signals before you clean the Product.**
- **Use only current probes, test leads, and adapters supplied with the Product.**
- **Remove test leads from the Product before the case is opened.**

Symbols used on the Product and in this manual are explained in Table 1.

Table 1. Symbols

Symbol	Description
	WARNING. RISK OF DANGER.
	WARNING. HAZARDOUS VOLTAGE. Risk of electric shock.
	Consult user documentation.
	Fuse
	Double Insulated
	Earth
	WARNING. Do not apply >550 Volts.
	Battery Status
CAT III	Measurement Category III is applicable to test and measuring circuits connected to the distribution part of the building's low-voltage MAINS installation.
CAT IV	Measurement Category IV is applicable to test and measuring circuits connected at the source of the building's low-voltage MAINS installation.
	Conforms to European Union directives.
	Certified by CSA Group to North American safety standards.
	Conforms to relevant Australian EMC standards.
	Certified by TÜV SÜD Product Service.
	This product complies with the WEEE Directive marking requirements. The affixed label indicates that you must not discard this electrical/electronic product in domestic household waste. Product Category: With reference to the equipment types in the WEEE Directive Annex I, this product is classed as category 9 "Monitoring and Control Instrumentation" product. Do not dispose of this product as unsorted municipal waste.

Specifications

Size	10.0 cm (L) x 25.0 cm (W) x 12.5 cm (H)
Weight (with batteries).....	1.3 kg
Battery	6 x AA Alkaline IEC LR6 Usable with 1.2 V NiMH batteries (not included)
Battery life (typical).....	200 hours idling
Fuse	T3.15 A, 500 V, IR: 1500 A
Operating Temperature.....	-10 °C to +40 °C
Storage Temperature	-10 °C to +60 °C (limited by battery specification) -40 °C for 100 hr
Relative Humidity	80 % 10 °C to 35 °C 70 % 35 °C to 40 °C
Altitude	
Operating	2 000 m
Storage.....	12 000 m
Vibration	MIL-PRF-28800F: Class 2
Ingress Protection	IEC 60529: IP 40
Safety	
IEC 61010-1	Pollution Degree 2
IEC 61010-2-030.....	300 V CAT IV, 500 V CAT III
Maximum voltage between any terminal and earth ground	500 V
IEC 61010-031 (Accessories)	
TP165X Remote Probe with cap.....	CAT IV 600 V, CAT III 1000 V, 10 A
TP165X Remote Probe without cap.....	CAT II 1000 V, 10 A
TL-L1, TL-L2, TL-L3 Test Leads	CAT IV 600 V, CAT III 1000 V, 10 A
Test Probes with cap.....	CAT IV 600 V, CAT III 1000 V, 10 A
Test Probes without cap.....	CAT II 1000 V, 10 A
AC285 Alligator Clip	CAT IV 600 V, CAT III 1000 V, 10 A
Country-Specific Mains Cord	CAT II 250 V, 1000 V dc
Electromagnetic Compatibility (EMC)	
International	IEC 61326-1: Portable CISPR 11: Group 1, Class A
	<i>Group 1: Equipment has intentionally generated and/or uses conductively-coupled radio frequency energy that is necessary for the internal function of the equipment itself.</i>
	<i>Class A: Equipment is suitable for use in all establishments other than domestic and those directly connected to a low-voltage power supply network that supplies buildings used for domestic purposes. There may be potential difficulties in ensuring electromagnetic compatibility in other environments due to conducted and radiated disturbances.</i>
	<i>Caution: This equipment is not intended for use in residential environments and may not provide adequate protection to radio reception in such environments.</i>
	<i>Emissions that exceed the levels required by CISPR 11 can occur when the equipment is connected to a test object.</i>
Wireless Radio with Adapter	
Frequency Range.....	2402 MHz to 2480 MHz
Output Power	<10 mW
Performance.....	EN61557-1, EN61557-2, EN61557-3, EN61557-4, EN61557-5, EN61557-6, EN61557-7, EN61557-10

Maximum Display Values

The following tables can be used for the determination of maximum or minimum display values considering maximum instrument operating uncertainty per EN61557-1, 5.2.4.

Insulation Resistance (R_{ISO})

50 V		100 V		250 V		500 V		1000 V	
Limit Value	Maximum Display Value	Limit Value	Maximum Display Value	Limit Value	Maximum Display Value	Limit Value	Maximum Display Value	Limit Value	Maximum Display Value
1	1.12	1	1.12	1	1.3	1	1.3	1	1.3
2	2.22	2	2.22	2	2.4	2	2.4	2	2.4
3	3.32	3	3.32	3	3.5	3	3.5	3	3.5
4	4.42	4	4.42	4	4.6	4	4.6	4	4.6
5	5.52	5	5.52	5	5.7	5	5.7	5	5.7
6	6.62	6	6.62	6	6.8	6	6.8	6	6.8
7	7.72	7	7.72	7	7.9	7	7.9	7	7.9
8	8.82	8	8.82	8	9.0	8	9.0	8	9.0
9	9.92	9	9.92	9	10.1	9	10.1	9	10.1
10	11.02	10	11.02	10	11.2	10	11.2	10	11.2
20	22.02	20	22.02	20	22.2	20	22.2	20	22.2
30	33.02	30	33.2	30	33.2	30	33.2	30	33.2
40	44.02	40	44.2	40	44.2	40	44.2	40	44.2
50	55.02	50	55.2	50	55.2	50	55.2	50	55.2
-	-	60	66.2	60	66.2	60	66.2	60	66.2
-	-	70	77.2	70	77.2	70	77.2	70	77.2
-	-	80	88.2	80	88.2	80	88.2	80	88.2
-	-	90	99.2	90	99.2	90	99.2	90	99.2
-	-	100	110.2	100	110.2	100	110.2	100	110.2
-	-	-	-	200	220.2	200	220.2	200	220.2
-	-	-	-	-	-	300	347	300	345
-	-	-	-	-	-	400	462	400	460
-	-	-	-	-	-	500	577	500	575
-	-	-	-	-	-	-	-	600	690
-	-	-	-	-	-	-	-	700	805
-	-	-	-	-	-	-	-	800	920
-	-	-	-	-	-	-	-	900	1035
-	-	-	-	-	-	-	-	1000	1150

Continuity (R_{LO})

Limit Value	Maximum Display Value	Limit Value	Maximum Display Value
0.2	0.16	3	2.68
0.3	0.25	4	3.58
0.4	0.34	5	4.48
0.5	0.43	6	5.38
0.6	0.52	7	6.28
0.7	0.61	8	7.18
0.8	0.7	9	8.08
0.9	0.79	10	8.98
1	0.88	20	17.98
2	1.78	30	26.8

Loop Tests (Z_I)

Loop Z_I Hi Current		Loop Z_I No Trip		Loop Z_I		Loop R_E	
Limit Value	Maximum Display Value	Limit Value	Maximum Display Value	Limit Value	Maximum Display Value	Limit Value	Maximum Display Value
0.20	0.14	-	-	3	2.53	3	2.72
0.30	0.23	-	-	4	3.38	4	3.62
0.40	0.32	0.40	0.28	5	4.23	5	4.52
0.50	0.41	0.50	0.37	6	5.08	6	5.42
0.60	0.50	0.60	0.45	7	5.93	7	6.32
0.70	0.59	0.70	0.54	8	6.78	8	7.22
0.80	0.68	0.80	0.62	9	7.63	9	8.12
0.90	0.77	0.90	0.71	10	8.48	10	9.02
1.00	0.86	1.00	0.79	20	16.98	20	18.02
1.10	0.95	1.10	0.88	30	25.3	30	27.2
1.20	1.04	1.20	0.96	40	33.8	40	36.2
1.30	1.13	1.30	1.05	50	42.3	50	45.2
1.40	1.22	1.40	1.13	60	50.8	60	54.2
1.50	1.31	1.50	1.22	70	59.3	70	63.2
1.60	1.40	1.60	1.30	80	67.8	80	72.2
1.70	1.49	1.70	1.39	90	76.3	90	81.2
1.80	1.58	1.80	1.47	100	84.8	100	90.2
1.90	1.67	1.90	1.56	200	169.8	200	180.2
2.00	1.76	2.00	1.64	300	253	300	272
-	-	-	-	400	338	400	362
-	-	-	-	500	423	500	452
-	-	-	-	600	508	600	542
-	-	-	-	700	593	700	632
-	-	-	-	800	678	800	722
-	-	-	-	900	763	900	812
-	-	-	-	1000	848	1000	902

RCD/FI Tests (ΔT , $I_{\Delta N}$)

RCD/FI Time		RCD/FI Current	
Limit Value	Maximum Display Value	Limit Value	Maximum Display Value
20	18.1	0.5	0.43
30	27.1	0.6	0.52
40	36.1	0.7	0.61
50	45.1	0.8	0.7
60	54.1	0.9	0.79
70	63.1	1	0.88
80	72.1	2	1.78
90	81.1	3	2.68
100	90.1	4	3.58
200	180.1	5	4.48
300	271	6	5.38
400	361	7	6.28
500	451	8	7.18
600	541	9	8.08
700	631	10	8.98
800	721	20	17.98
900	811	30	26.8
1000	901	40	35.8
2000	1801	50	44.8
-	-	60	53.8
-	-	70	62.8
-	-	80	71.8
-	-	90	80.8
-	-	100	89.8
-	-	200	179.8
-	-	300	268
-	-	400	358
-	-	500	448

Earth Tests (R_E)

Limit Value	Maximum Display Value	Limit Value	Maximum Display Value
10	8.8	200	179.8
20	17.8	300	268.0
30	26.8	400	358.0
40	35.8	500	448.0
50	44.8	600	538.0
60	53.8	700	628.0
70	62.8	800	718.0
80	71.8	900	808.0
90	80.8	1000	898.0
100	89.8	2000	1798.0

Electrical Measurement Specifications

The specification for maximum permissible error (MPE) is defined as (% reading + digit counts) at 23 °C ±5 °C, ≤80 % RH. Between -10 °C and 18 °C and between 28 °C and 40 °C, MPE specifications may degrade by 0.1 x (MPE specification) per °C. The specifications apply up to one year from the date of calibration.

AC Voltage Measurement (V)

Range	Resolution	Accuracy 45 Hz – 66 Hz	Input Impedance	Overload Protection
500 V	0.1 V	0.8 % + 3	320 kΩ	550 V rms

Insulation Resistance Measurement (Riso)

Test Voltages		MPE of Test Voltage (at rated test current)
Model 1662	Model 1663 Model 1664	
100-250-500-1000 V	50-100-250-500-1000 V	+10 %, -0 %

Test Voltage	Insulation Resistance Range	Resolution	Test Current	MPE Specification
50 V	10 kΩ to 50 MΩ	0.01 MΩ	1 mA @ 50 kΩ	±(3 % + 3 digits)
100 V	100 kΩ to 20 MΩ	0.01 MΩ	1 mA @ 100 kΩ	±(3 % + 3 digits)
	20 MΩ to 100 MΩ	0.1 MΩ		±(3 % + 3 digits)
250 V	10 kΩ to 20 MΩ	0.01 MΩ	1 mA @ 250 kΩ	±(1.5 % + 3 digits)
	20 MΩ to 200 MΩ	0.1 MΩ		±(1.5 % + 3 digits)
500 V	10 kΩ to 20 MΩ	0.01 MΩ	1 mA @ 500 kΩ	±(1.5 % + 3 digits)
	20 MΩ to 200 MΩ	0.1 MΩ		±(1.5 % + 3 digits)
	200 MΩ to 500 MΩ	1 MΩ		±10 %
1000 V	100 kΩ to 200 MΩ	0.1 MΩ	1 mA @ 1 MΩ	±(1.5 % + 3 digits)
	200 MΩ to 1000 MΩ	1 MΩ		±10 %

Note: The number of insulation tests with a new set of batteries is >2000.

Auto Discharge	Discharge time constant <0.5 second for C = 1 μF or less.
Live Circuit Detection	Inhibits test if terminal voltage >30 V prior to initiation of test.
Maximum Capacitive Load	Operable with up the 5 μF load.

Insulation Safety Pretest	Connections from the Tester to L, N, and PE are required.
----------------------------------	---

Continuity Testing (RLo)

Range (Autoranging)	Resolution	Open Circuit Voltage	MPE Specification
20 Ω	0.01 Ω	>4 V	±(1.5 % + 3 digits) ^[1]
200 Ω	0.1 Ω	>4 V	±(1.5 % + 3 digits)
2000 Ω	1 Ω	>4 V	±(1.5 % + 3 digits)
<p>[1] For 10 mA, add 3 digits. Note: The number of 250 mA @ 1 Ω continuity tests with a set of new batteries is >1500.</p>			

Range Setting	Display Range	Test Current ^[1]
250 mA	0.2 Ω to 2.0 Ω	250 mA
	2 Ω to 160 Ω	250 mA to 50 mA
	160 Ω to 800 Ω	10 mA
	800 Ω to 2000 Ω	2 mA
10 mA	0 Ω to 800 Ω	10 mA
	800 Ω to 2000 Ω	2 mA
<p>[1] All test currents ±10 %.</p>		

Test Probe Zeroing	Press ZERO to zero the test probe. Can subtract up to 3 Ω of lead resistance. Error message for >3 Ω.
Live Circuit Detection	Inhibits test if terminal voltage >10 V ac detected prior to initiation of test.

Mains Wiring Indicator

Icons (⚡↔, ⚡↔, ⚡↔) indicate if L-PE or L-N terminals are reversed. Loop and RCD tests are inhibited and an error code is generated if the input voltage is not between 100 V and 500 V. The UK Loop and RCD tests are inhibited if the L-PE or the L-N terminals are reversed.

Loop and Line Impedance (Z_l No Trip and Hi Current)

Mains Input Voltage Range	100 - 500 V ac (45/66 Hz)
Input Connection (soft key selection)	Loop Impedance: phase to earth
	Line impedance: phase to neutral
Limit on Consecutive Tests	Automatic shutdown when the temperature of internal components is too hot.
Maximum Test Current @ 400 V	20 A sinusoidal for 10 ms
Maximum Test Current @ 230 V	12 A sinusoidal for 10 ms

Range	Resolution	MPE Specification ^[1]
10 Ω ^[3]	0.001 Ω	Hi Current m Ω mode: $\pm(2\% + 15 \text{ digits})$
20 Ω	0.01 Ω	No Trip mode: $\pm(3\% + 6 \text{ digits})$
		Hi Current mode: $\pm(2\% + 4 \text{ digits})$
200 Ω	0.1 Ω	No Trip mode: $\pm(3\%)$
		Hi Current mode: $\pm(2\%)$
2000 Ω	1 Ω	$\pm 6\%$ ^[2]
Notes [1] Valid for resistance of neutral circuit <20 Ω and up to a system phase angle of 30°. Test leads must be zeroed before testing. [2] Valid for mains voltage >200 V. [3] 1664 FC only.		

Prospective Earth Fault Current (PEFC)

Prospective Short Circuit Current (PSC)

Computation	Prospective Earth Fault Current (PEFC/ I_K) or Prospective Short Circuit Current (PSC/ I_K) determined by dividing measured mains voltage by measured loop (L-PE) resistance or line (L-N) resistance, respectively.	
Range	0 kA to 50 kA	
Resolution and Units	Resolution	Units
	$I_K < 1000 \text{ A}$	1 A
	$I_K > 1000 \text{ A}$	0.1 kA
Accuracy	Determined by accuracy of loop resistance and mains voltage measurements.	

RCD Testing

RCD Types Tested

Limit on consecutive tests: Automatic shutdown for RCD tests when the temperature of internal components is too hot.

RCD Type ^[6]		Model 1662	Model 1663	Model 1664
AC ^[1]	G ^[2]	•	•	•
AC	S ^[3]	•	•	•
A ^[4]	G	•	•	•
A	S	•	•	•
B ^[5]	G		•	•
B	S		•	•

[1] AC – Responds to ac
 [2] G – General, no delay
 [3] S – Time delay
 [4] A – Responds to pulsed signal
 [5] B – Responds to smooth dc
 [6] RCD test inhibited for V >265 ac
 RCD tests permitted only if the selected current, multiplied by earthing resistance, is <50 V.

Test Signals

RCD Type	Test Signal Description
AC (sinusoidal)	The waveform is a sinewave starting at zero crossing, polarity determined by phase selection (0 ° phase starts with low to high zero crossing, 180 ° phase starts with high to low zero crossing). The magnitude of the test current is $I_{\Delta n} \times \text{Multiplier}$ for all tests.
A (half wave)	The waveform is a half wave rectified sinewave starting at zero, polarity determined by phase selection (0 ° phase starts with low to high zero crossing, 180 ° phase starts with high to low zero crossing). The magnitude of the test current is $2.0 \times I_{\Delta n} \text{ (rms)} \times \text{Multiplier}$ for all tests for $I_{\Delta n} = 0.01\text{A}$. The magnitude of the test current is $1.4 \times I_{\Delta n} \text{ (rms)} \times \text{Multiplier}$ for all tests for all other $I_{\Delta n}$ ratings.
B (DC)	This is a smooth dc current according to EN61557-6 Annex A

RCD Tripping Indicator

The RCD ✓ symbol switches on as a “good test” indicator when testing the RCD trip time or RCD trip current if the trip time meets the following conditions:

RCD Type	$I_{\Delta N}$	Trip Time Limits
G	x 1	Less than 300 ms
S	x 1	Between 130 ms and 500 ms
G	x 5	Less than 40 ms
S	x 5	Between 50 ms and 150 ms

RCD Tripping Time (ΔT)

Test Function	RCD Current Selection						
	10 mA	30 mA	100 mA ^[1]	300 mA ^[1]	500 mA ^[1]	1000 mA ^[2]	Var ^[3]
x ½, 1	•	•	•	•	•	•	•
x 5	•	•	•				
Ramp	•	•	•	•	•	•	•
Auto	•	•	•				

Mains voltage 100 V – 265 V ac, 45/66 Hz
 [1] Type B RCDs require mains voltage range of 195 V – 265 V.
 [2] Type AC RCDs only.
 [3] Type A RCDs are limited to 700 mA, not available for Type B RCDs.

Current Multiplier	RCD Type ^[1]	Measurement Range		Trip Time MPE Specification
		Europe	UK	
x ½	G	310 ms	2000 ms	±(1 % Reading + 1 ms)
x ½	S	510 ms	2000 ms	±(1 % Reading + 1 ms)
x 1	G	310 ms	310 ms	±(1 % Reading + 1 ms)
x 1	S	510 ms	510 ms	±(1 % Reading + 1 ms)
x 5	G	50 ms	50 ms	±(1 % Reading + 1 ms)
x 5	S	160 ms	160 ms	±(1 % Reading + 1 ms)

[1] G – General, no delay / S – Time delay

RCD Tripping Current ($I_{\Delta N}$) Measurement/Ramp Test

Current Range	Step Size	Dwell Time		MPE Specification
		Type G	Type S	
30 % to 110 % of RCD rated current ^[1]	10 % of $I_{\Delta N}$ ^[2]	300 ms/step	500 ms/step	±5 %
<p>[1] 30 % to 150 % for Type A $I_{\Delta N} > 10$ mA 30 % to 210 % for Type A $I_{\Delta N} = 10$ mA 20 % to 210 % for Type B Specified trip current ranges (EN 61008-1): 50 % to 100 % for Type AC 35 % to 140 % for Type A (>10 mA) 35 % to 200 % for Type A (≤10 mA) 50 % to 200 % for Type B</p> <p>[2] 5 % for Type B</p>				

Phase Sequence Test

Icon	 icon. Phase Sequence indicator is active.
Display of Phase Sequence	Displays "1-2-3" in digital display field for correct sequence. Displays "3-2-1" for incorrect phase. Dashes in place of a number indicate a valid determination could not be made.
Mains Input Voltage Range (phase-to-phase)	185 V to 500 V

Earth Resistance Test (R_E)

Models 1663 and 1664 FC only.

Range	Resolution	MPE Specification
200 Ω	0.1 Ω	±(2 % + 5 digits)
2000 Ω	1 Ω	±(3.5 % + 10 digits)

Range: $R_E + R_{PROBE}$ ^[1]	Test Current
2200 Ω	3.5 mA
16000 Ω	500 μ A
52000 Ω	150 μ A
[1] Without external voltages	

Frequency	Output Voltage
128 Hz	25 V

Live Circuit Detection	Inhibits test if terminal voltage >10 V ac is detected prior to start of test.
-------------------------------	--

Auto Test Sequence

Models 1664 FC only.

Meets the specifications of the individual tests.

Operating Ranges and Uncertainties per EN 61557

The Operating Uncertainty shows the maximum permissible error as a percent of reading when all uncertainty influence factors E1-E10 are counted.

Function	Display Range	EN 61557 Measurement Range Operating Uncertainty	Nominal Values
V EN 61557-1	0.0 V ac – 500 V ac	50 V ac – 500 V ac ±(2 % + 2 digits)	UN = 230/400 V ac f = 50/60 Hz
RLO EN 61557-4	0.00 Ω - 2000 Ω	0.2 Ω - 2000 Ω ±(10 % + 2 digits)	4.0 V dc <UQ <24 V dc RLO ≤2.00 Ω IN ≥200 mA
RISO EN 61557-2	0.00 MΩ - 1000 MΩ	1 MΩ - 200 MΩ ±(10 % + 2 digits) 200 MΩ - 1000 MΩ ±(15 % + 2 digits)	UN = 50 / 100 / 250 / 500 / 1000 V dc IN = 1.0 mA
ZI EN 61557-3	ZI (No Trip) 0.00 Ω - 2000 Ω	0.4 Ω - 2000 Ω ±(15 % + 6 digits)	UN = 230/400 V ac f = 50/60 Hz IK = 0 A – 10.0 kA
	ZI (Hi Current) 0.00 Ω - 2000 Ω	0.2 Ω - 200 Ω ±(10 % + 4 digits)	
	ZI (Hi Current, Hi Res) 0 mΩ - 9999 mΩ	100 mΩ - 9999 mΩ ±(8 % + 20 digits)	
	RE 0.00 Ω - 2000 Ω	10 Ω - 1000 Ω ±(10 % + 2 digits)	
ΔT, IΔN EN 61557-6	ΔT 0.0 ms – 2000 ms	25 ms – 2000 ms ±(10 % + 1 digits)	ΔT @ 10 / 30 / 100 / 300 / 500 / 1000 / Var mA
	IΔN 3 mA – 550 mA (VAR 3 mA – 700 mA)	3 mA – 550 mA ±(10 % + 1 digits)	IΔN = 10 / 30 / 100 / 300 / 500 / Var mA
RE EN 61557-5	0.0 Ω - 2000 Ω	10 Ω - 2000 Ω ±(10 % + 2 digits)	f = 128 Hz
Phase EN 61557-7			1 : 2 : 3

Operating Uncertainties per EN 61557

The Operating Uncertainty shows the maximum permissible uncertainty as a percent of reading when all uncertainty influence factors E1-E10 are counted.

	Volts	RLo EN 61557-4	RISO EN 61557-2	ZI EN 61557-3	ΔT EN 61557-6	I Δ N EN 61557-6	RE EN 61557-5
Intrinsic Uncertainty A	0.80 %	1.50 %	10.00 %	6.00 %	1.00 %	5.00 %	3.50 %

Influence Quantity	Volts	RLo EN 61557-4	RISO EN 61557-2	ZI EN 61557-3	ΔT EN 61557-6	I Δ N EN 61557-6	RE EN 61557-5
E1 - Position	0.00 %	0.00 %	0.00 %	0.00 %	0.00 %	0.00 %	0.00 %
E2 - Supply Voltage	0.50 %	3.00 %	3.00 %	3.00 %	3.00 %	2.75 %	2.00 %
E3 - Temperature	0.50 %	3.00 %	3.00 %	3.00 %	3.00 %	2.25 %	1.50 %
E4 - Series Interferences Voltage	-	-	-	-	-	-	2.00 %
E5 - Resistance of the probes and auxiliary earth electrodes	-	-	-	-	-	-	4.60 %
E6.2 - System phase angle	-	-	-	1.00 %	-	-	-
E7 - System frequency	0.50 %	-	-	2.50 %	-	-	0.00 %
E8 - System voltage	-	-	-	2.50 %	2.50 %	2.50 %	0.00 %
E9 - Harmonics	-	-	-	2.00 %	-	-	-
E10 - D.C. Quantity	-	-	-	2.50 %	-	-	-

Required Equipment

Before you start the verification procedures or make calibration adjustments, refer to this section for the equipment, system, and setup requirements.

See Table 2 for a list of requirements for the verification tests of the Tester.

Table 2. Required Equipment

Equipment	Model	Notes
Calibrator	5320A	
Precision DMM	8846A	
PC	---	
IR Adapter Cable	with DB9 connector	Fluke P/N 1590638
	with USB connector	Fluke P/N 2166275
Zero Adapter	Fluke-165XB-8001, Zero Adapter	Fluke P/N 3301338

Basic Maintenance

This section contains information about the basic maintenance of the Tester.

⚠⚠ Warning

To prevent possible electrical shock, fire, or personal injury:

- Remove the input signals before you clean the product.
- Remove all probes, test leads, and accessories before the case is opened.
- Use only specified replacement parts.

Clean the Tester

⚠⚠ Warning

To prevent electrical shock or damage to the Tester, never allow water inside the case.

⚠ Caution

To prevent damage to the housing, never apply abrasives or solvents to the Tester.

To keep the case clean, periodically wipe the case with a damp cloth and mild detergent.

Dirt or moisture in the input jacks can affect readings.

To clean the input jacks:

1. Turn off the Tester and remove all test leads.
2. Shake out any dirt that may be in the input jacks.
3. Soak a new swab with alcohol. Work the swab around each input jack.

Test and Replace Batteries

⚠ Caution

To prevent incorrect measurements, replace the batteries when the low battery indicator shows.

The Tester continuously monitors Battery voltage. If the voltage falls below 6.0 V (1.0 V/cell), the low battery icon (⚡) appears on the display to indicate that minimal battery life remains. The low battery icon remains on the display until you replace the batteries. Replace the batteries with six AA batteries. Alkaline batteries are supplied with the Tester but you can also use 1.2 V NiMH batteries.

You can also manually test the battery charge and replace batteries before they discharge.

To manually test the batteries:

1. Turn the rotary switch to the V position.
2. Press and hold (Ⓜ) to initiate the battery test. The Voltage function display clears and is replaced by the measured battery voltage in the secondary display until released.

To replace the batteries (refer to Figure 1):

1. Press Ⓢ to turn off the Tester.
2. Remove the test leads from the input jacks.
3. Use a standard flat-blade screwdriver to turn the battery door screws (3) one-quarter turn counterclockwise.
4. Remove the battery door.
5. Press the release latch and slide the battery holder out of the Tester.
6. Replace the batteries and the battery door.

⚠ Caution

To prevent loss of the Tester settings, complete the battery replacement within 1 minute.

7. Turn the screws one-quarter turn clockwise to secure the door.

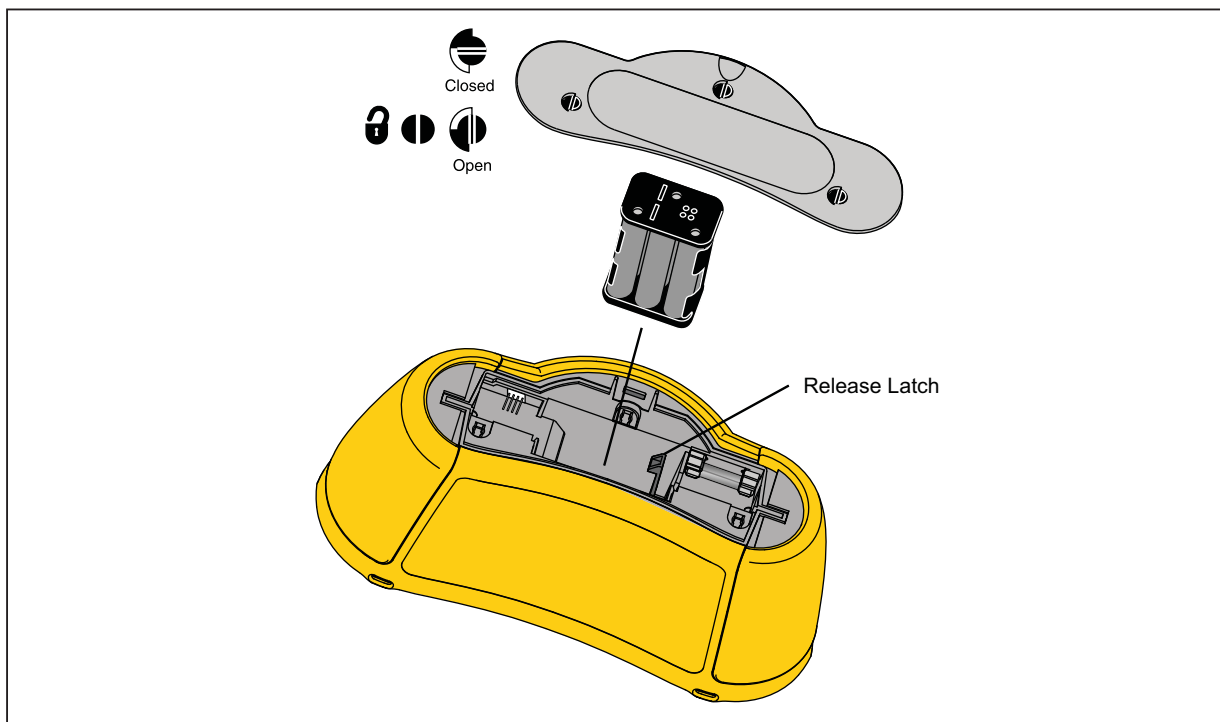

Figure 1. Battery Replacement

Fuse Test

To check the fuse:

1. Turn the rotary switch to **R_{LO}**.
2. Select the input as L-PE.
3. Short the L-PE leads.
4. Press and hold TEST .

If the fuse is bad, FUSE shows on the display to indicate the Tester is damaged and needs repair. Contact Fluke Service for repair (see *How to Contact Fluke* on page 1).

Performance Tests

Use these performance tests to make sure that the Tester, is in proper operating condition. The tests check the accuracy of each Tester function against the specifications. To do the tests you will need the equipment listed in Table 2. Before you begin the accuracy tests, allow the Tester to stabilize to room temperature. Depending on temperature gradient, this can take several hours.

If the Tester fails any of these tests, it needs calibration adjustment or repair.

Backlight Test

To test that the backlight circuit works:

1. Press Ⓢ to turn on the Tester.
2. Press Ⓢ once to turn on the backlight.
3. Press Ⓢ a second time to turn off the backlight

LCD Test

To test all LCD segments and the display contrast quality:

1. Press Ⓢ to turn off the Tester.
2. While holding down Ⓢ , turn on the Tester.
3. Continue to hold Ⓢ down after releasing Ⓢ .
4. Compare the display segments on the Tester to Figure 2. Check for any missing segments or poor contrast areas.

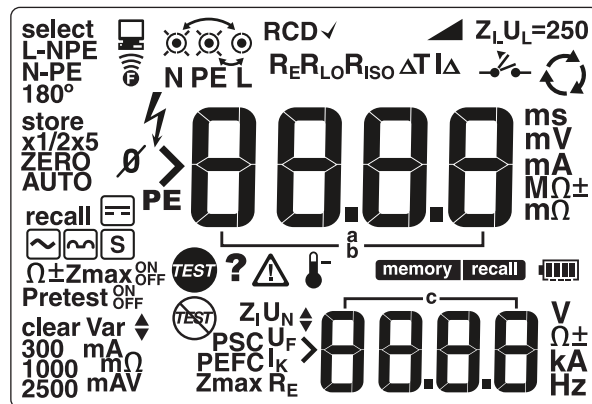



Figure 2. LCD Tests

IR Port Verification

Note

You can do this verification procedure with Windows® 98 or later. If you are successfully using MET/CAL for reading data over the IR port, it is not necessary to do this verification test.

To verify the IR port:

1. Connect the Infrared Serial Cable to a COM port on the PC and on the Tester.
2. Press .
3. Set the rotary switch to any function.
4. On the PC, launch a terminal program and set up the following:
 - Name: 166X IR Port Test
 - Connect the COM port on the PC that connects to the 166x
 - Bits per second: 9600
 - Data bits: 8
 - Parity: None
 - Stop bits: 1
 - Flow control: None
5. Enter the identification command <ID> followed by <Enter>.

The Tester should return the response:

FLUKE 166X, VX.XX/X.XX, XXXXXXXX

(indicates the model, software version, and unit serial number)

Note

If the PC indicates that the Tester is not connected, ensure that the COM port is correct and that the IR Serial Cable is properly connected.

Touch Pad Sense Test

Warning

To prevent exposure to dangerous voltage:

- Do this test correctly.
- Do not do this test unless you are qualified to do so.

The Touch Pad measures the potential between the operator and the PE input jack. If the potential exceeds 100 V, the  (Warning) symbol illuminates. Do this test to verify that the Touch Pad circuit works properly (see Figure 3):

1. Connect the PE input jack on the Tester to the HI terminal on the Calibrator V, HI Ω , mA~ Output.
2. Connect the Calibrator LO terminal to a test lead with test probe attached at the opposite end.
3. Set the Calibrator output for 100 V, 50 Hz. Leave the Calibrator in Standby mode.
4. Place a Touch Plate (PN 1884378) onto the Touch Pad and touch with the probe as shown in Figure 3.
5. Set the Calibrator to operate and note that the  symbol illuminates on the Tester front panel.

- Set the Calibrator to standby and remove the test leads and probe from the Tester and calibrator.

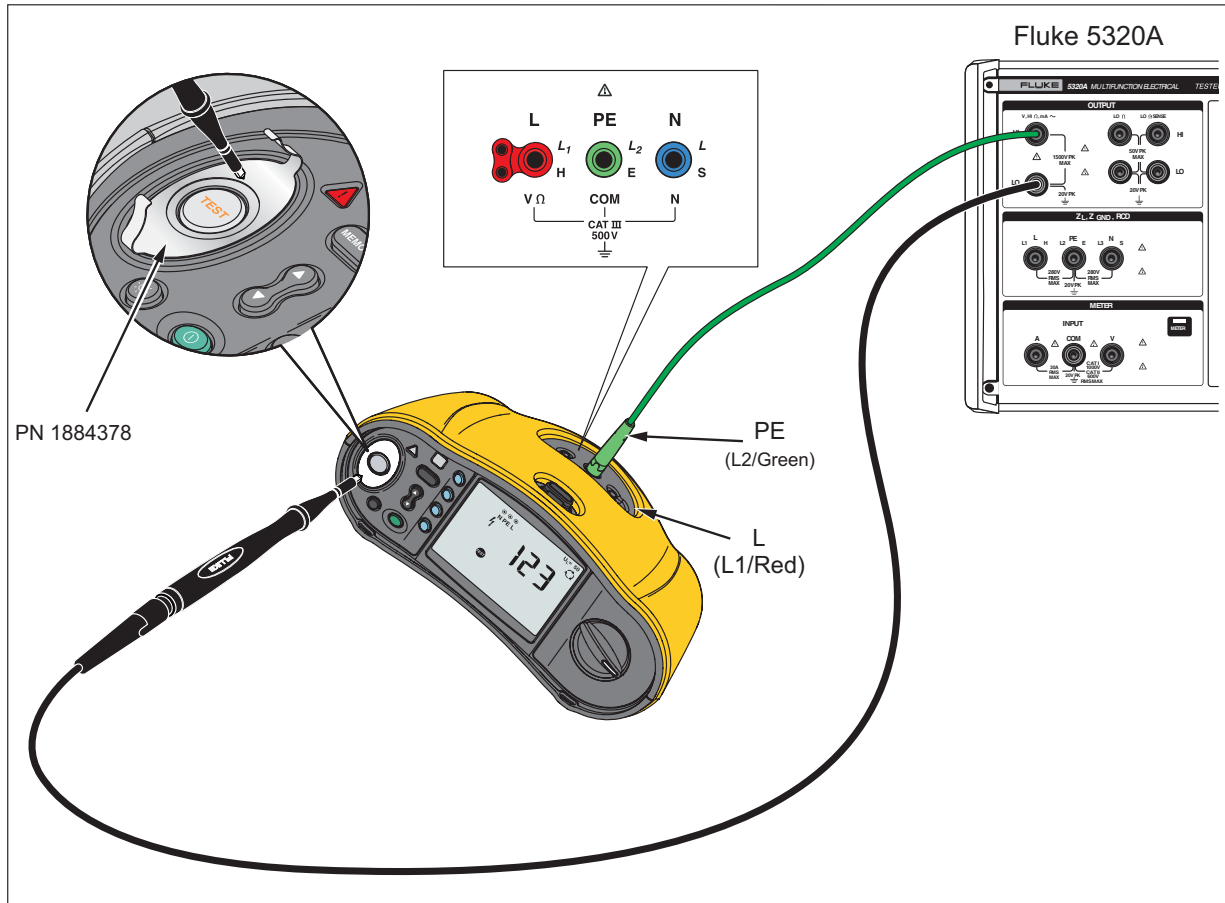

Figure 3. Touch Pad Sense Test

Memory Mode Test

To verify the proper function of the Memory Mode:

- Turn the rotary switch to **V**.
- Connect the PE and L input jacks of the Tester to the Calibrator V, HI Ω , mA \sim Output terminals as shown in Figure 4.
- Set the Calibrator for the Volts function and apply 25 V, 50 Hz to the Tester.
- Press **MEMORY** to enter Memory Mode.
- Use **F1** and **⏏** to set the data identity.
- Press **F2** to save the data.

To recall the saved data:

- Press **MEMORY** to re-enter Memory Mode.
- Use **F1** and **⏏** to set the data identity.
- Press **F3** twice to recall the data. The recalled data should match the saved value.

Battery Gauge Test

To verify the low battery detection:

1. Turn off the Tester.
2. Remove the test leads from the terminals.
3. Use a standard-blade screwdriver to turn the battery door screws (3) one-quarter turn counterclockwise and remove the battery door.
4. Press the release latch and slide the battery holder out of the Tester.
5. Connect a variable supply and set 6.5 V to the battery contacts. Positive lead is closest to the fuse.
6. Turn on the Tester on and verify that the battery indicator shows 1 bar.
7. Turn off the Tester.
8. Disconnect the power supply.
9. Replace the batteries.
10. Replace the battery holder and the battery door.
11. Turn the battery door screws one-quarter turn clockwise to fasten the door.

Accuracy Tests

Volt and Insulation Functions

To verify the accuracy of the volt function:

1. Turn the rotary switch to **VOLTS V**.
2. Press F until L-PE appears in the upper left corner of the display.
3. Connect the L and PE input jacks on the Tester to the Calibrator V, HI Ω , mA~ Output terminals as shown in Figure 4.
4. Apply the Input Level for steps 1 through 6 in Table 3.
5. Compare the Tester display reading with the Display Reading limits in Table 3.
6. Set the Calibrator to STBY .

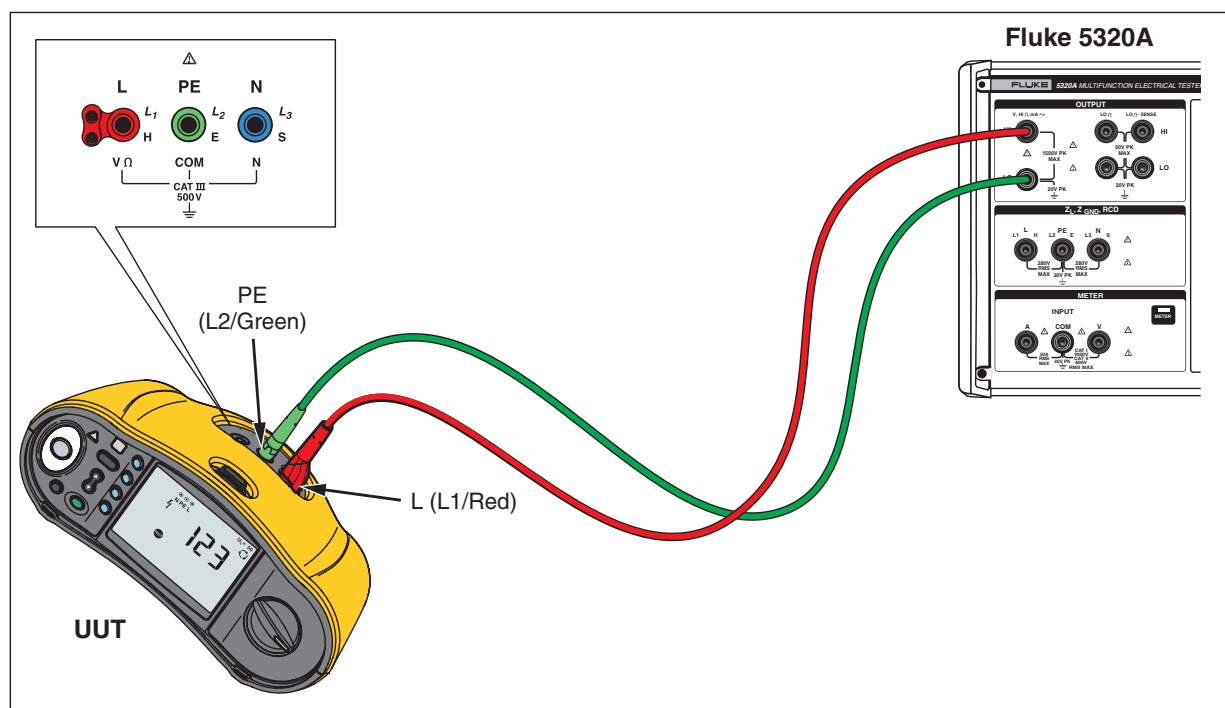

Figure 4. Volts and Insulation Accuracy Tests

Table 3. Volts AC Accuracy Tests

Step	Function	Range	Input Level	Input Source Frequency ^[1]	Display Reading	
					Lower Limit	Upper Limit
1	Volts, AC	500 V	4 V	45 Hz to 66 Hz	3.7	4.3
2			10.5 V	45 Hz to 66 Hz	10.1	10.9
3			20 V	45 Hz to 66 Hz	19.5	20.5
4			230 V	45 Hz to 66 Hz	227.9	232.1
5			495 V	45 Hz to 66 Hz	490.7	499.3
6			505 V	45 Hz to 66 Hz	>500 V ac	>500 V ac

[1] The 5320A uses the local line frequency.

To verify the accuracy of the insulation function:

1. Turn the rotary switch to **INSULATION R_{ISO}**.
2. Disconnect the calibrator and short L to PE to N.
3. For 1664 FC only:
 - a. Press (F3) to turn off the Pretest.
 - b. Press (F4) to set the range to 50 V
 - c. Press (F1) to set testing N-PE.
 - d. Press (TEST). Reading must be <0.03 MΩ.
 - e. Press (F1) to set the test to L-N.
 - f. Press (TEST). Reading must be <0.03 MΩ.
 - g. Press (F1) to set the test to L-PE.
4. Press (TEST). Reading must be <0.03 MΩ.
5. On the Tester, connect:
 - L to **Precision DMM HI**.
 - PE to **Precision DMM LO**.
6. Set the Precision DMM to measure DC Volts.
7. To test the output voltage of the Tester, set the Range for steps 1 through 5 of the Insulation function in Table 4.
8. Press (TEST) to start each measurement.
9. Compare the Precision DMM display reading with the Display Reading Limits in Table 4.
10. On the Calibrator, add the connection:
 - HI Ω HI output to Tester L
 - HI Ω LO to the Tester PE
11. Set the Calibrator to HI Ω.
12. Apply the Input Level for steps 6 through 10 of the Insulation function in Table 4.
13. Press (TEST) to start each measurement. The test current shown on the calibrator should be >1 mA.
14. Compare the Precision DMM display reading and the Tester lower display voltage reading with the Display Reading Limits in Table 4.
15. Disconnect the Precision DMM. The Tester connection is now to the Calibrator only.
16. Start at step 11 (step 13 for 1662) and apply the input level for the steps in Table 4.
17. Press (TEST) to start each measurement.
18. Compare the Tester display reading with the Display Reading Limits in Table 4.

Table 4. Insulation Accuracy Tests

Step	Function	Range	Input Level	Model	Display Reading	
					Lower Limit	Upper Limit
1	IEC61557	50 V	none	1663 and 1664 FC only	50 V	62 V
2	IEC61557	100 V	none	all	100 V	125 V
3	IEC61557	250 V	none	all	250 V	312 V
4	IEC61557	500 V	none	all	500 V	625 V
5	IEC61557	1000 V	none	all	1000 V	1250 V
6		50 V	50 k Ω	1663 and 1664 FC only	50 V	55 V
7		100 V	100 k Ω	all	100 V	110 V
8		250 V	250 k Ω	all	250 V	275 V
9		500 V	500 k Ω	all	500 V	550 V
10		1000 V	1 M Ω	all	1000 V	1100 V
11		50 V	0.05 M Ω	1663 and 1664 FC only	0.02 M Ω	0.08 M Ω
12		50 V	48 M Ω	1663 and 1664 FC only	46.53 M Ω	49.47 M Ω
13		100 V	0.1 M Ω	all	0.07 M Ω	0.13 M Ω
14		100 V	19 M Ω	all	18.40 M Ω	19.60 M Ω
15		100 V	96 M Ω	all	92.8 M Ω	99.2 M Ω
16		250 V	0.25 M Ω	all	0.22 M Ω	0.28 M Ω
17		250 V	19 M Ω	all	18.69 M Ω	19.32 M Ω
18		250 V	196 M Ω	all	192.8 M Ω	199.2 M Ω
19		500 V	0.5 M Ω	all	0.46 M Ω	0.54 M Ω
20		500 V	19 M Ω	all	18.69 M Ω	19.32 M Ω
21		500 V	196 M Ω	all	192.8 M Ω	199.2 M Ω
22		500 V	225 M Ω	all	203 M Ω	248 M Ω
23		1000 V	0.1 M Ω	all	0.0 M Ω	0.4 M Ω
24		1000 V	1 M Ω	all	0.7 M Ω	1.3 M Ω
25		1000 V	195 M Ω	all	191.8 M Ω	198.2 M Ω

Continuity Function

To verify accuracy of the continuity function:

1. Turn the rotary switch to **CONTINUITY R_{LO}**.
2. On the Tester:
 - a. Connect L to **Precision DMM HI**.
 - b. Connect PE to **Precision DMM LO**.
 - c. Press (F1) to set L-PE.
 - d. Press (F3) to set $\Omega+$.
3. Set the Precision DMM to measure DC Volts.
4. Press (TEST). Voltage reading on the precision DMM must be >4 V and <24 V.
If Voltage is negative, tester has firmware version 1.07/1.05. Later versions of the firmware use a positive voltage.
5. On the Precision DMM:
 - a. Connect Tester L to **Precision DMM 400 mA** jack.
 - b. Set the Precision DMM to measure mA DC.
6. If needed, press (F4) to set 10 mA.
7. Press (TEST). The current reading must be between 9 mA and 11 mA (or between -9 mA and -11 mA for earlier firmware version).
8. Press (F4) to set 250 mA.
9. Press (TEST). The current reading must be between 225 mA and 275 mA (or between -225 mA and -275 mA for earlier firmware version).
10. Press (F3) to set $\Omega-$.
11. Press (TEST). The current reading must be between -225 mA and -275 mA (or between 225 mA and 275 mA for earlier firmware version).
12. On the Calibrator, connect the measurement test leads to the Tester N and PE (L and PE for 1662) input jacks in a 4-wire configuration as shown in Figure 5.
13. Press (F4) to set 10 mA. If needed, press (F1) to display N-PE (L and PE for 1662).
14. On the Calibrator:
 - a. Set to LO Ω .
 - b. Set mode to Short.
 - c. Press (OPER).
15. Press and hold (F2) until the Tester displays a reading and the ZERO \emptyset annunciator.
16. Set the Calibrator to 4 wire Ohms Mode. Set to step 1 conditions in Table 5.
17. Press (F3) to set $\Omega+$.
18. Press (TEST) and compare the display reading with the Display Reading limits for step 1 in Table 5.
19. Follow the instructions in Table 5.
20. Apply the Calibrator Output values for the remaining steps in Table 5, and press (TEST).
21. Compare each display reading with the Tester Display Reading limits in Table 5.

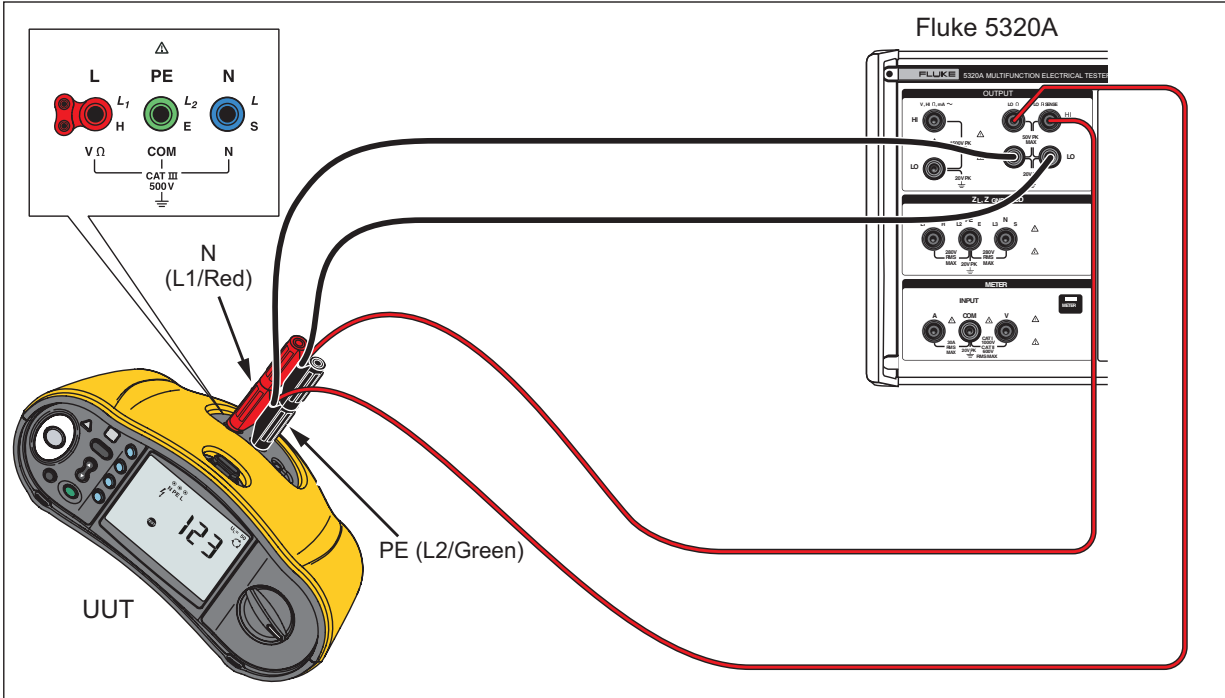

Figure 5. Continuity Tests (4-Wire Connection)

Table 5. Continuity Accuracy Tests

Step	Test Current Setting	Range	Calibrator Output	Tester Display Reading	
				Lower Limit	Upper Limit
1	10 mA / N-PE (L and PE for 1662)	20	1 Ω	0.92	1.08
For 1662: Skip Step 2.					
2	a. Move PE connections to L. b. Press F1 to display L-N. c. Set Calibrator to LO Ω Short. d. Press F2 to zero. e. Return to 4 wire mode. f. Go to step 3.				
3	10 mA / L-N (L and PE for 1662)	20	18 Ω	17.67	18.33
For 1662: Skip Step 4.					
4	a. Move N connections to PE. b. Press F1 to display L-PE. c. Set Calibrator to LO Ω Short. d. Press F2 to zero. e. Return to 4 wire mode. f. Go to step 5.				
5	10 mA	20	5 Ω	4.86	5.14
6	a. Press F4 to set 250 mA mode. b. Set Calibrator to LO Ω Short. c. Press F2 to zero. d. Return to 4 wire mode. e. Go to step 7.				
7	250 mA	20	2 Ω	1.94	2.06
8		20	5 Ω	4.89	5.11
9		200	19.65 Ω	19.33	19.97
10		200	100 Ω	98.2	101.8
11		2000	196.5 Ω	193.3	199.7
12		2000	1965 Ω	1933	1997

LOOP Z₁ NO TRIP, L-PE

To verify the LOOP Z₁ NO TRIP, L-PE accuracy, complete the following procedure.

⚠⚠ Warning

To prevent possible electrical shock, fire, or personal injury, do not touch the L or N input jacks while performing the following tests. These input jacks have line voltage on them during the test.

To verify LOOP Zero:

1. Set the rotary switch to **LOOP Z₁ NO TRIP** function.
2. Use (F1) to select the L-PE test.
3. Short the far end of the test leads together with a Zero Adapter (Fluke P/N 3301338). See Figure 7.
4. Press and hold (F2) for 3 seconds until the ZERO ∅ annunciator shows.
5. On the Calibrator:
 - a. Select **Z_L**.
 - b. Use the Mode softkey to select **Loop**.
 - c. Use the Setup softkey to select **Loop Impedance** and then select **Loop imp. correction** and **COMP**.
 - d. Use the Setup softkey to select **Loop Serial Resistance** to 0.000.

For each step in Table 6:

1. Connect the test leads to the Tester and Calibrator, as shown in Figure 6.
2. Set the rotary switch to **LOOP Z₁ NO TRIP** function.
3. Use (F1) to select L-PE.
4. On the Calibrator:
 - a. Set the Calibrator to source the nearest loop impedance value to the nominal value in Table 6.
 - b. Record the Displayed OUTPUT impedance value for step 1 of Table 6.
5. Use the Tester Accuracy Spec. and the Recorded 5320A Displayed Output impedance value to calculate the Upper and Lower Tester display limits for Step 2 with this formula:
 (Recorded Calibrator Displayed OUTPUT Z Value) ± {(Recorded Calibrator Displayed OUTPUT Z Value) x Tester Accy. Spec.] + Tester Spec. digits}
6. Set the Calibrator **Loop Impedance** to the next step value.
7. Put the Calibrator in OPER and wait for the reading to settle.
8. Press and release (TEST) and record the display reading.
9. Compare the display reading to the Upper and Lower limits calculated in Table 6.
10. Repeat step 6 through step 9 for the remaining steps of Table 6.
11. Set the Calibrator to **STBY**.

Table 6. LOOP Z₁ NO TRIP Accuracy Tests

Step	Tester Function	Ⓜ Setting	Calibrator Nominal Loop Impedance	Calibrator Residual Impedance Correction Type	Recorded Calibrator Displayed OUTPUT Z Value	Tester Accuracy Spec. ±(% + dig)	Tester Res.	Tester Display Reading	
								Lower Limit	Upper Limit
1	LOOP Z ₁ NO TRIP	L-PE	0.50 Ω	COMP		±(3 % + 6)	0.01		
2			18 Ω			±(3 % + 6)	0.01		
3			180 Ω			±3 %	0.1		
4			1800 Ω			±6 %	1		

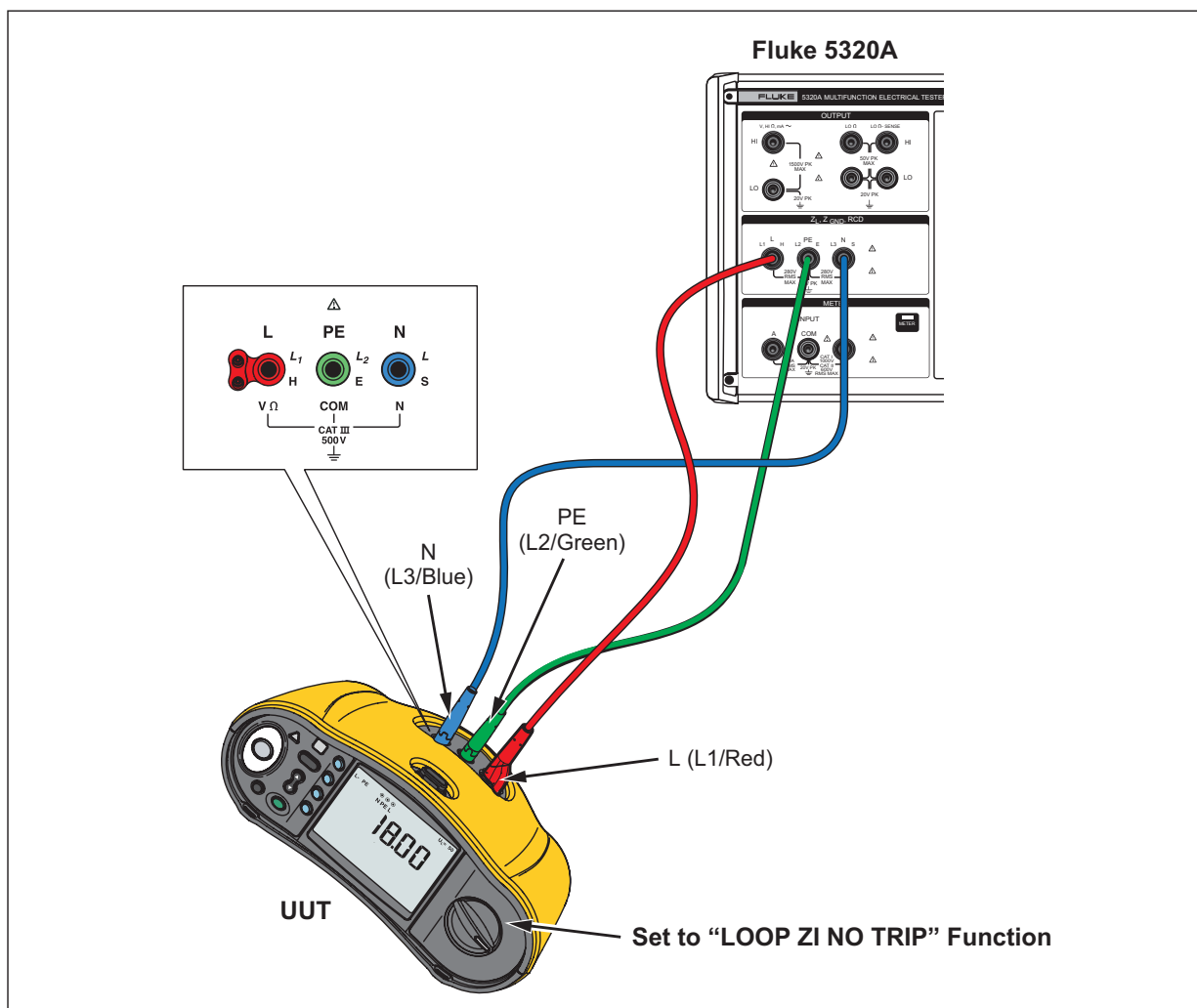

Figure 6. LOOP Z₁ NO TRIP Test

Loop Z_i Hi Current

⚠⚠ Warning

To prevent possible electrical shock, fire, or personal injury, do not touch the L or N input jacks while performing the following tests. These input jacks have line voltage on them during the test.

To do a LOOP Zero test:

1. Short the far end of the test leads together with a Zero Adapter (Fluke P/N 3301338) See Figure 7.
2. Press and hold **F2** for 3 seconds until the ZERO \emptyset annunciator shows.
3. On the Calibrator:
 - a. Select **Z_L**.
 - b. Use the Mode softkey to select **Line (Loop)**.
 - c. Use the Setup softkey to select **Line Impedance (Loop Impedance)** and then select **Line (Loop) imp. correction** and **COMP**.
 - d. Use the Setup softkey to select **Line Serial Resistance** to 0.000.

For each step in Table 7:

1. Connect the test leads to the Tester and Calibrator. See Figure 8.
2. Set the rotary switch to **LOOP Z_i HI CURRENT** function.
3. Press **F1** to set L-PE.
4. Press **F4** to get the mΩ indicator for Table 7, step 1 and 2. For step 3 in Table 7, press **F4** to get the Ω indicator.
5. On the Calibrator:
 - a. Use the cursor keys or keypad to set the Nominal R Value (approximate) for the value from Table 7.
 - b. Record the Displayed OUTPUT impedance value.
6. Use the Tester accuracy spec. and the recorded Calibrator Displayed Output impedance value to calculate the Upper and Lower Tester display limits for Table 7 with this formula:
 (Recorded Calibrator Displayed OUTPUT Z Value) ± {[(Recorded Calibrator Displayed OUTPUT Z Value) x %] + Counts}
7. Put the Calibrator in OPER and wait for the reading to settle.
8. Press and release **TEST** and note the display reading.

9. Compare the display reading to the calculated display limits in Table 7.

Table 7. Loop Z_l Hi Current Accuracy Tests

Step	Tester Function	Ⓜ Setting	Calibrator Nominal R Value	Calibrator Residual Impedance Correction Type	Recorded Calibrator Displayed Output Z Value	Tester Accuracy Spec. (% + digit)	Tester Res.	Calculated Tester Display Reading	
								Lower Limit	Upper Limit
1	Loop Z _l Hi Current	L-PE	0.5 Ω	Comp		10 Ω Range ± (2 % +15)	0.001 Ω		
2			1.0 Ω						
3			0.5 Ω			20 Ω Range ± (2 % +4)	0.01 Ω		
4			18 Ω						
5			180 Ω			± 2 %	0.1 Ω		
6			1800 Ω			±6 %	1 Ω		
7		On the calibrator, use the Mode button to select Line, then select. Press Ⓜ to set L-N mode.							
8	L-N		180 Ω	Comp		+2 %	0.1 Ω		
9			1800 Ω			+6 %	1 Ω		

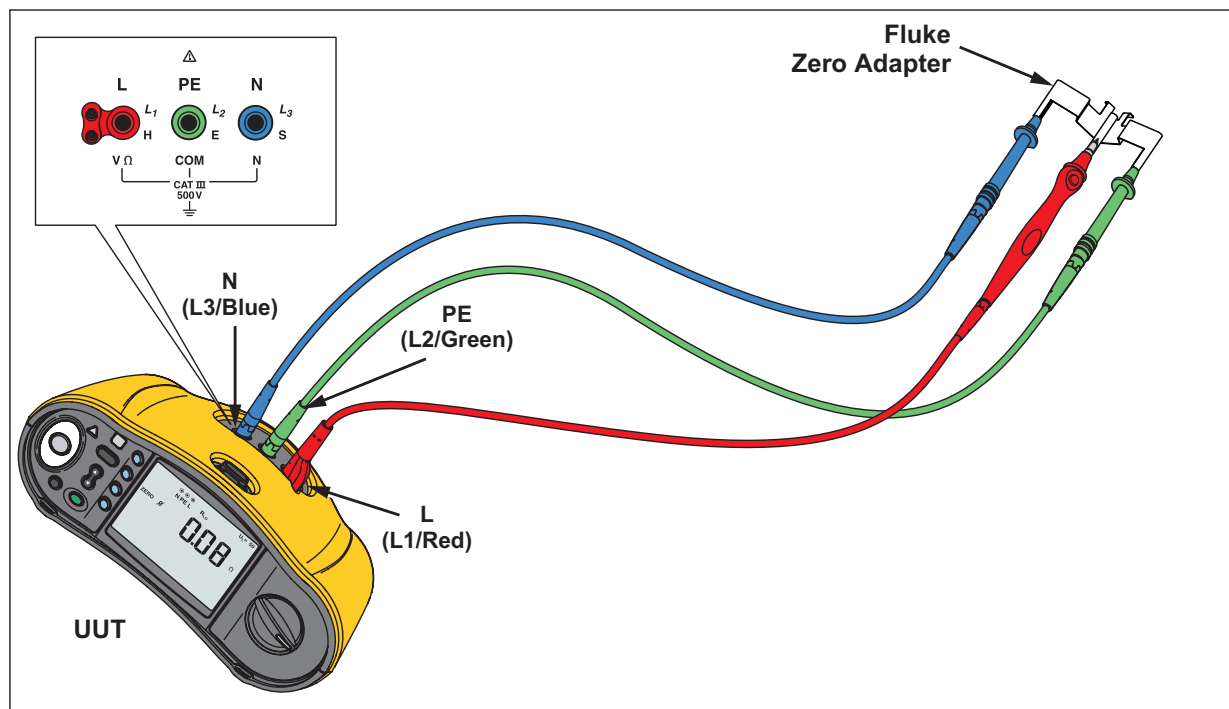



Figure 7. Loop Zero Tests

RCD Trip Current

⚠⚠ Warning











To prevent possible electrical shock, fire, or personal injury, do not touch the L or N input jacks while performing the following tests. These input jacks carry line voltage during the test.



To test the RCD trip current accuracy, do this procedure for each step in Table 8.

1. Connect L, PE, and N from the Tester to the Calibrator as shown in Figure 8.
2. Turn the rotary switch to the ΔT function.
3. Set (F1), (F2), and (F3) to the values shown in Table 8.
4. ON the Calibrator, press  and use the MODE key and Cursor key to select **Trip Current**.
5. Press the Calibrator softkey to select Trip I. Use the cursor keys to modify the Trip I to the same value as the RCD nominal trip current ((F1) setting) on the Tester.
6. Put the Calibrator in OPER and wait for the reading to settle.
7. Press .
8. Compare the measured RCD trip current (or Maximum value Parameter) on the Calibrator display to the Current Accuracy limits in Table 8.

If the Calibrator does not trip, press the **Clear** softkey on the Calibrator to clear the maximum value.

Table 8. RCD Trip Current Accuracy Tests

Step	Tester Function	Tester Settings				Specification Lower, Upper Limit	Current Accuracy	
		(F1)	(F2)	(F3)	(F4)		Lower Limit	Upper Limit
1	ΔT	0°	x1/2		10 mA	-10 %, +0 %	4.50	5.00
2		0°	x1/2		10 mA	-10 %, +0 %	3.18	3.54
3		0°	x5		10 mA	-0 %, +10 %	50.0	55.0
4		0°	x1		30 mA	-0 %, +10 %	30.0	33.0
5		180°	x1		30 mA	-0 %, +10 %	30.0	33.0
6		0°	x1		30 mA	-0 %, +10 %	42.4	46.7
7		0°	x1/2		30 mA	-10 %, +0 %	13.5	15.0
8 ^[1]		0°	x1		30 mA	-0 %, +10 %	60	66
9 ^[1]		180°	x1		30 mA	-0 %, +10 %	60	66
10 ^[1]		0°	x1		300 mA	-0 %, +10 %	600	660
11		0°	x1		1000 mA	-0 %, +10 %	1000	1100

[1] Steps 8-10 = 1664 FC only.
 = AC
 = A
 = B

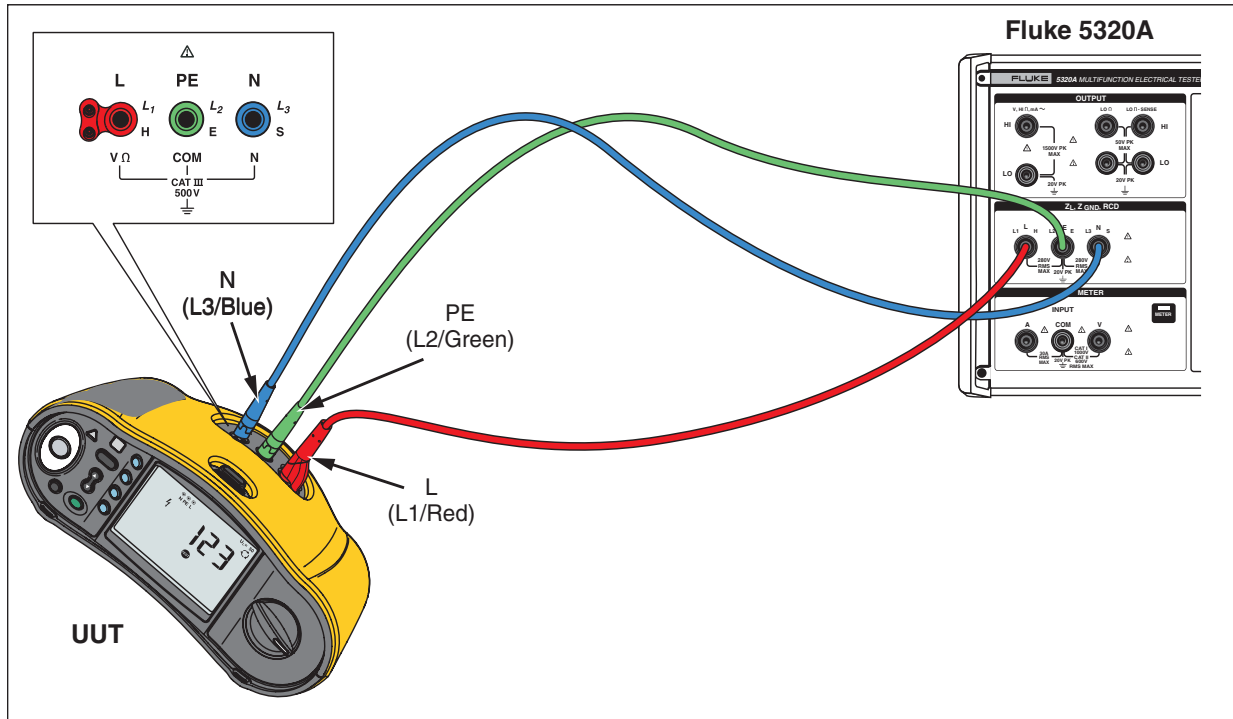

Figure 8. Loop Z_1 Hi Current Line Impedance and RCD Tests

RCD Trip Time

⚠⚠ Warning

To prevent possible electrical shock, fire, or personal injury, do not touch the L or N input jacks while performing the following tests. These input jacks carry line voltage during the test.

To test the RCD Trip Time Accuracy, do this procedure for each step in Table 9.

1. Connect L, PE, and N from the Tester to the Calibrator as shown in Figure 8.
2. Turn on the Tester and set the rotary switch to the ΔT function.
3. Set (F1), (F2), (F3) to the values shown in Table 9.
4. On the Calibrator, press **RCD** and use the MODE softkey and Cursor keys to select Trip Time.
5. Press the Calibrator softkeys to select **Trip I** and **I Mult**.
6. Use the cursor keys to modify the **Trip I** and **I Mult** to the same value as the (F4) and (F2) setting on the Tester.
7. Put the Calibrator in **OPER** and wait for the reading to settle.
8. Press **TEST**.
9. Compare the measured trip time to the Accuracy limits in Table 9.

Table 9. RCD Trip Time Accuracy Tests

Step	Tester Function	Calibrator RCD Trip Time	Tester Settings			Specification	Trip Time Accuracy	
			(F2)	(F3)	(F4)		Lower Limit	Upper Limit
1	ΔT	30 ms	x1	~	30 mA	1 % + 1	28.7	31.3
2		300 ms	x1	~	30 mA	1 % + 1	296.0	304.0
3		500 ms	x1	~ S	30 mA	1 % + 1	494.0	506.0

~ = AC
 ~ S = AC S

Earth Resistance (1663/1664 FC)

To verify accuracy for earth resistance measurements:

1. Turn the rotary switch to the R_E Earth function.
2. Connect the Tester to the Calibrator LO Ω Output terminals as shown in Figure 9.
3. On the Calibrator, press the $\overline{LO\Omega}$ function.
4. Press the Calibrator MODE softkey and then select "Resistance 4-Wire" using the cursor keys and Select softkey.
5. Use the Calibrator numeric keypad to enter the resistance values in Table 10.
6. Put the Calibrator in \overline{OPER} .
7. Press TEST and compare the reading to the display limits in Table 10.

Table 10. Earth Resistance Test

Step	Tester Function	Calibrator Res. Value	Specification	Tester Display Reading	
				Lower Limit	Upper Limit
1	R_E Earth	2 Ω	2 % + 5	1.5	2.5
2		1800 Ω	3.5 % + 10	1737	1863

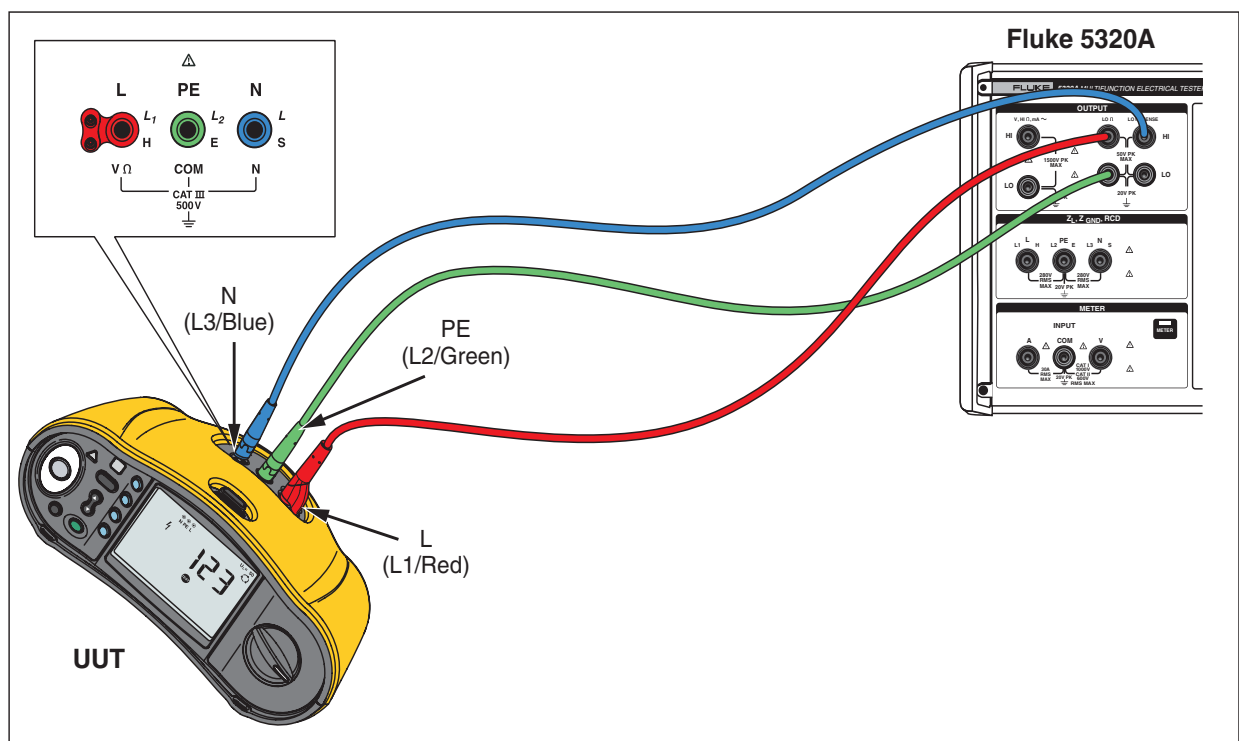

Figure 9. Earth Resistance Tests

Accessories and Replaceable Parts

See Table 11 and Figure 10 for accessories and user-replaceable parts. See *How to Contact Fluke* on page 1 to order parts.

⚠⚠ Warning

For safe operation and maintenance of the product, use only specified replacement parts.

Table 11. Accessories and Replaceable Parts

Item	Description	Fluke PN	QTY
1	Battery, Primary, Alkaline, 1.5 V, 2.4 Ah, AA, Set of 3	2771610	2
2	Battery Holder	1676850	1
3	Battery Door	4601799	1
4	⚠ Fuse, 3.15 A, 500 V, IR: 1500 A, Slow, 6.35 x 32 mm (not user replaceable)	---	2
5	Zero Adapter	3261925	1
6	Carry Strap for Neck and Waist	4502043	1
7	TP165X, Test Probe with Remote Test Button	2107742	1
8	Standard Test Lead Set (with leads, probes, caps, and alligator clips)	2107756	1
not shown	Probe Cap, GS-38 Red	1942029	1
not shown	Cable IRDA Optical to USB, 1.65 m	2166275	1
9	Mains Test Cord, Schuko (EU)	4601081	1
	Mains Test Cord, Italy	4601096	1
	Mains Test Cord, Switzerland	4601107	1
	Mains Test Cord, UK	4601070	1
	Mains Test Cord, Denmark	4601129	1
	Mains Test Cord, Australia	4601118	1
9	Mains Test Cord, North America	4601134	1
10	Tool Box (Hard Case with foam insert)	4688513	1
not shown	CD with User Manual 1662/1663/1664 FC	4477435	1
⚠ For safety, use exact replacement only.			

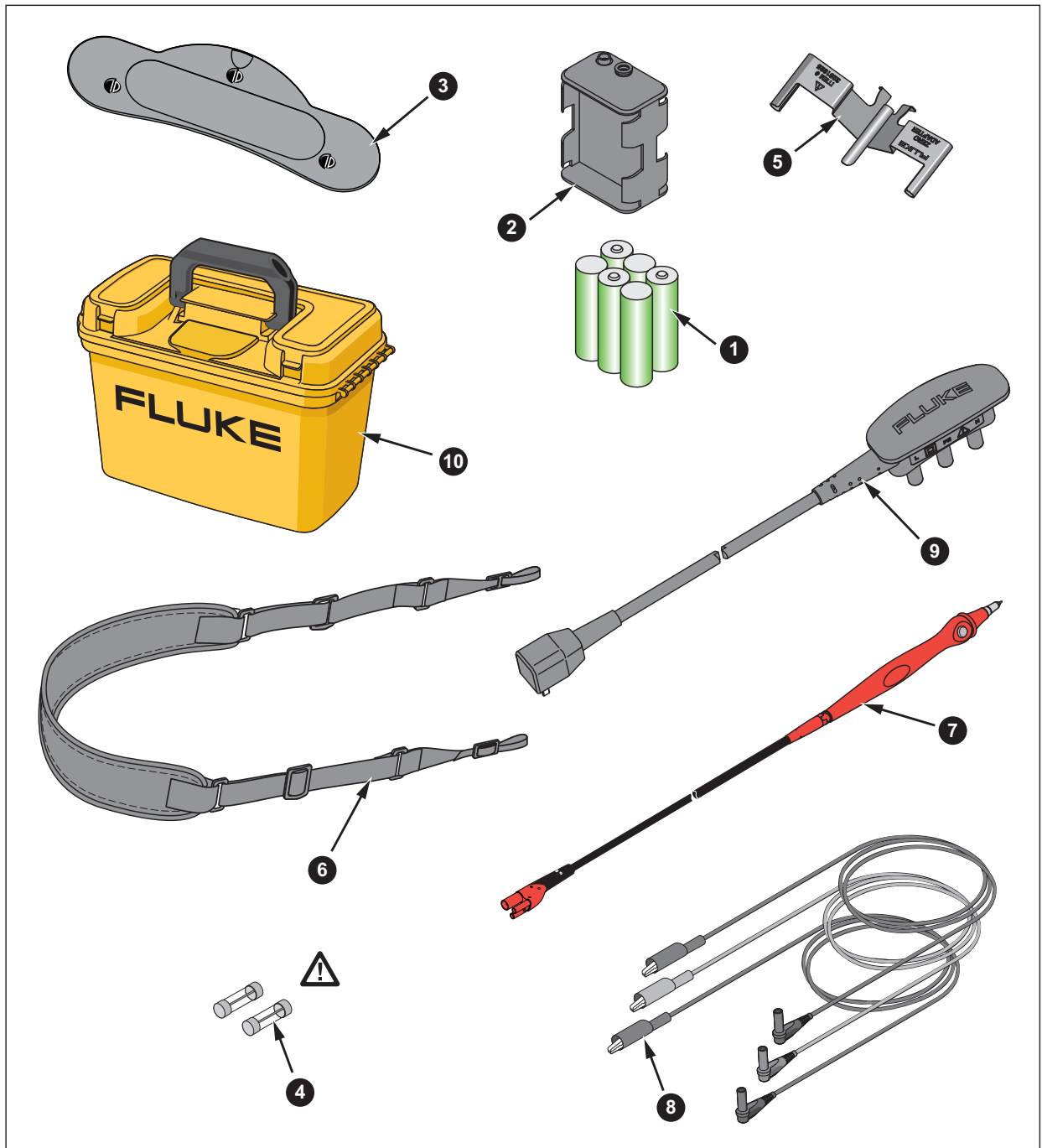

Figure 10. Accessories and Replaceable Parts

