

Fluke Power Quality tools shed light on the blackout of 2003

Application Note

Few facilities in the United States have escaped a power interruption during the course of their operation. Construction crews sever underground power feeds, vehicles strike power poles, and storms bring down distribution networks. Even routine maintenance by a power company in a nearby area disturbs power availability if circuits are taken offline to facilitate a repair operation. Despite the fact that minor power outages occur frequently, the Blackout of 2003 was a sudden wake up call for many.

On Thursday, August 14, 2003, the lights went out over much of the northeastern United States and southeast Canada. Many major metropolitan areas were affected including Toronto and Ottawa, Canada, Erie PA, Cleveland OH, and Detroit MI. Power was lost to over 85% of New York state as well as major cities in New Jersey, Vermont, and Connecticut. The blackout ultimately affected an estimated 50-million people.

Using power quality monitoring instrumentation, the North American Electric Reliability Council (NERC, Princeton, NJ) and the joint Canadian/North American task force set out to pinpoint a cause and make recommendations for preventing a reoccurrence. From the beginning, Fluke power quality analysis instruments were on the job.

Becoming part of the investigation

Fluke Corp., (Everett WA) the world's leading manufacturer of electronic test tools and software for maintenance of critical systems, purchased Reliable Power Meters (RPM) in 2002 and formed Fluke Power Quality. Fluke Power Quality provides portable and installed quality instruments for both in-depth analysis and fast troubleshooting. Their power quality analysis instruments — Power Recorder, Multipoint, and Insite — provided both quality data and analysis critical to determination of the causes for the grid failure. All Fluke Power Quality and RPM three-phase power quality tools provide Full Disclosure Technology (FDT), which use patented sampling hardware and algorithms to record everything a user's load sees. This ensures that the data collected is absolutely complete, making it more valuable in the problem solving and analysis arena and fully adaptable to helping analyze and solve the blackout event of 2003.

Easy setup

Full Disclosure monitoring is the ability to measure all aspects of power quality, on every voltage cycle, and record them in appropriate detail over the duration of a power study. Full Disclosure monitoring delivers clear visibility into all characteristics of a power system that affect critical loads and provides users with a high confidence-level look at the relative health of their power system.

With FDT-based monitoring the need for setting thresholds, ranges, and sampling rates is eliminated. The monitors feature a simple setup process that makes it unlikely that a user will miss sub-cycle events, no matter how fleeting or critical. Complicated setup procedures frustrate users and often lead to improper instrument setup. If threshold and sampling rates are incorrectly set, the monitor may not record any useful data, or worse yet, completely miss a rare intermittent event.

When doing a power quality survey, users may have little idea of what to expect in the way of threshold values needed for their analysis. Setting correct limits and for what type of events may require lots of previous experience or, in a worse case scenario, an educated guess as what the thresholds values should be.



The Blackout of 2003 not only affected 50 million people but also countless industrial and commercial sites.

At this point, not all technologies are created equal. If thresholds must be set, as with older technology instruments, and are set either too high or too low, the monitor either misses significant events or collects too much and runs out of memory or paper. The key here is to provide a large memory capacity, as in FDT devices, so that all changes in critical parameters can be captured.

Flexibility counts

Another important feature of full disclosure monitors is “adaptive threshold” technology. In order to balance what data is collected vs. the possibility of memory overflow, full disclosure monitors start at very low values. If the rate of incoming events will cause its memory to overflow before the monitoring period is over, the monitor’s software raises the thresholds in 0.125-volt increments on successive cycles to regulate the rate of capture. If event activity slows, internal software lowers the thresholds incrementally by the same amount. Essentially, the monitor constantly adjusts threshold levels without the intervention of an operator to match the event activity and rate of capture to memory capacity.

In order to effectively judge power quality and achieve Full Disclosure as to what is happening on the line, many measurements must be processed simultaneously and in real time. These critical parameters and events include:

- RMS voltage and current
- Power and power consumption, including Watts, VA, VAR, Power Factor (PF), Displacement Power Factor (DPF), Demand, and KWH
- Voltage sags, swells, and outages
- Voltage transients
- Voltage imbalance
- Flicker
- Ground current
- Harmonic distortion

Root mean square measurements (RMS) are used as a basis for determining many of the parameters listed above. Power monitors using analog RMS measurement techniques average measurements over several cycles and can miss cycle-to-cycle variations. Compare this to FDT-based monitors that use digital signal processing to measure RMS and harmonic distortion on every cycle and on all voltage and current channels. This improved method provides measurement such as Watts, VA, VAR, and PF that are derived from every cycle and processed in real time.

The accuracy of power consumption and harmonics measurements depends not only on the sampling rates achievable using Full Disclosure Technology but also on processing throughput. Because these units feature digital signal processing technology, they also have the computational power to measure every cycle, opening a “full window” to the calculation process.

Sub-cycle events often important

If Full Disclosure is to be achieved in any power monitoring situation, the monitor must be able to analyze everything from a five-minute outage to a 200-msec transient using the same instrument during the same monitoring session. Sampling rates and the design of the sampling system are critical to capturing these and other associated events necessary in helping the user get a sense for the source of the disturbance.

For example, monitors equipped with peak detect circuitry can capture both the amplitude and phase of the transients, but cannot display the shape of its wave form. However, FDT-based units use high-speed digital signal processing systems that can both capture transients and display their waveforms, similar to a digital oscilloscope. As the old saying goes, “A picture is worth a thousand words.”

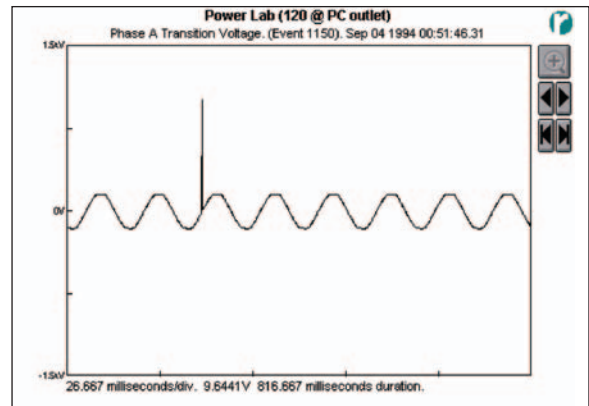

Figure 1 illustrates a peak detect impulse capture. When set at a sampling rate of 8 kHz, which permits capture of transients and impulses down to 130-msec duration, it is adequate for capturing power factor capacitor switching transients but not fast enough for recording high-speed impulses that occur inside facilities due to loads (motors, etc.) turning on and off.

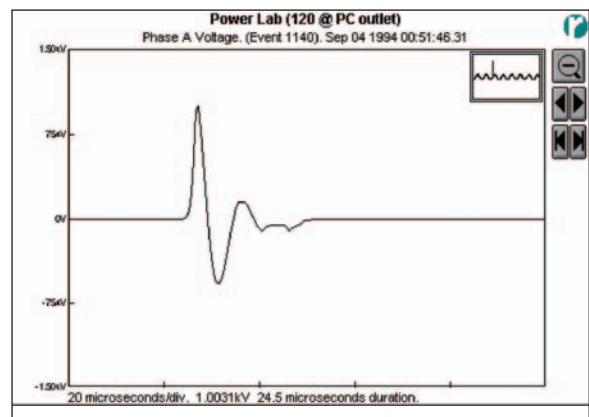

Figure 2 provides a look at the same capture as seen using high-speed analog-to-digital sampling techniques at rates of 1-MHz or more using Full Disclosure technology. The waveform that could provide the key to power problem analysis is clearly visible.

Getting the most for the data

Power tolerance curves provide an indication of the likelihood that an electrical event will cause an equipment failure. Power tolerance curves plot event magnitude vs. event duration. The longer the duration of an event and the more extreme it is, the more likely it is to cause a problem. Which curve is used depends on parameters that include equipment sensitivity and monitoring point.

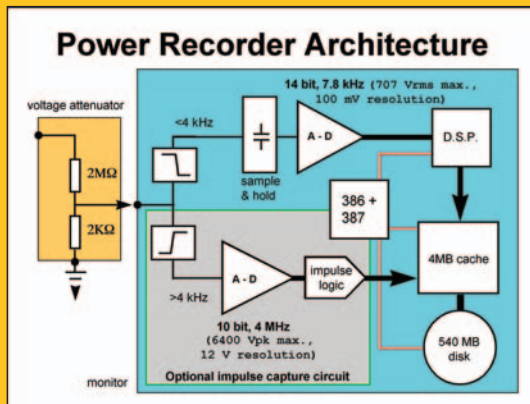

Figure 3. Sampling system architecture.

Full disclosure monitoring – how it works

The architecture of a full disclosure monitor includes an onboard digital signal processor, an internal hard disk drive, an embedded microprocessor, a floating-point coprocessor, and 4 MB of RAM. In service, its 8 KHz sample-and-hold circuit and 14-bit analog-to-digital (A-D) converter takes a one-cycle "snapshot" on four voltage and 5 current channels and provides 128 samples per cycle.

The digital signal processor performs a Fourier Transform on the sampled waveform data to the 63rd harmonic in 100 msec. This process is repeated every cycle. From the harmonics data, all other parameters including RMS, Watts, VA, VAR, Power Factor, THD, etc. are also calculated. These are then logged to provide long-term summary graphs with single-cycle resolution. Cycle-by-cycle data is then summarized to show the maximum and minimum, as well as average values, recorded on a single cycle.

A parallel signal path leads high-frequency events toward a 2 Msample per second A-D converter. Digitized transient data is stored in the cache memory and time-correlated with RMS and other cycle-by-cycle measurements.

The ANSI curve defines the maximum excursions of voltage with respect to time that can be expected at the service entrance from the utility. Power tolerance curves such as the CBEMA – see accompanying diagram – and the newer ITIC curve describe the sensitivity of electronic equipment. All are extremely useful in overall power quality analysis. Essentially, power tolerance curves allow users to spot worst-case events. Automatically set thresholds make sure that all significant events are captured for later superimposition on a power tolerance curve if necessary. Customized curve fitting and editing allow users to easily check power delivery systems, making certain that they are performing within their required tolerances. Full Disclosure technology also lends itself to easy thorough reporting in a wide variety of formats.

Full disclosure – where to get it

Fluke Power Quality manufactures a wide variety of monitors that feature Full Disclosure technology. The RPM Power Recorder is a portable monitor. In addition to the Full Disclosure technology, it features four voltage channels – three phases plus neutral to

ground – that measure up to 600 Vrms, 1,000 Vpeak. It has five current channels, allowing both neutral to ground and phase monitoring. The ability to capture up to 6,000 voltage events simultaneously or in a multi-session option for up to 16 sessions or 96,000 events, 128 samples/cycle – on every cycle, and an optional 2 Ms/sec sampling system are built into the architecture of the instrument. The RPM Power Recorder also supports single phase wye, delta, split-phase, high-leg delta, open-leg delta, and other common power systems. Downloading uses an Ethernet interface. Packaging includes an extruded metal enclosure, Nylon and hard-sided cases, mounting brackets, and a wide variety of current probes.

For permanently installed monitors, Full Disclosure capability can be supplied by either the compact RPM InSite device or the RPM Multipoint high-speed recorder. Both work with either Fluke's Power Analysis or Scenario Software. Both can measure and trend power and power consumption parameters including Watts, VA, VAR, PF, and kWh. They can also measure and track harmonics up to the 63rd. Electrical connection and basic packaging features are similar for all monitors in the RPM family.

Fluke. Keeping your world up and running.

Fluke Corporation
PO Box 9090, Everett, WA USA 98206

Fluke Europe B.V.
PO Box 1186, 5602 BD
Eindhoven, The Netherlands

For more information call:
In the U.S.A. (800) 443-5853 or
Fax (425) 446-5116
In Europe/M-East/Africa (31 40) 2 675 200 or
Fax (31 40) 2 675 222
In Canada (800) 36-FLUKE or
Fax (905) 890-6866
From other countries +1 (425) 446-5500 or
Fax +1 (425) 446-5116
Web access: <http://www.fluke.com>

©2003 Fluke Corporation. All rights reserved.
Printed in U.S.A. 12/2003 2127563 A-US-N Rev A