

AF2082

A-Frame Cable Ground Fault Locator

Users Manual

LIMITED WARRANTY AND LIMITATION OF LIABILITY

Each Fluke product is warranted to be free from defects in material and workmanship under normal use and service. The warranty period is two years and begins on the date of shipment. Parts, product repairs, and services are warranted for 90 days. This warranty extends only to the original buyer or end-user customer of a Fluke authorized reseller, and does not apply to fuses, disposable batteries, or to any product which, in Fluke's opinion, has been misused, altered, neglected, contaminated, or damaged by accident or abnormal conditions of operation or handling. Fluke warrants that software will operate substantially in accordance with its functional specifications for 90 days and that it has been properly recorded on nondefective media. Fluke does not warrant that software will be error free or operate without interruption.

Fluke authorized resellers shall extend this warranty on new and unused products to end-user customers only but have no authority to extend a greater or different warranty on behalf of Fluke. Warranty support is available only if product is purchased through a Fluke authorized sales outlet or Buyer has paid the applicable international price. Fluke reserves the right to invoice Buyer for importation costs of repair/replacement parts when product purchased in one country is submitted for repair in another country.

Fluke's warranty obligation is limited, at Fluke's option, to refund of the purchase price, free of charge repair, or replacement of a defective product which is returned to a Fluke authorized service center within the warranty period. To obtain warranty service, contact your nearest Fluke authorized service center to obtain return authorization information, then send the product to that service center, with a description of the difficulty, postage and insurance prepaid (FOB Destination). Fluke assumes no risk for damage in transit. Following warranty repair, the product will be returned to Buyer, transportation prepaid (FOB Destination). If Fluke determines that failure was caused by neglect, misuse, contamination, alteration, accident, or abnormal condition of operation or handling, including overvoltage failures caused by use outside the product's specified rating, or normal wear and tear of mechanical components, Fluke will provide an estimate of repair costs and obtain authorization before commencing the work. Following repair, the product will be returned to the Buyer transportation prepaid and the Buyer will be billed for the repair and return transportation charges (FOB Shipping Point).

THIS WARRANTY IS BUYER'S SOLE AND EXCLUSIVE REMEDY AND IS IN LIEU OF ALL OTHER WARRANTIES, EXPRESS OR IMPLIED, INCLUDING BUT NOT LIMITED TO ANY IMPLIED WARRANTY OF MERCHANTABILITY OR FITNESS FOR A PARTICULAR PURPOSE. FLUKE SHALL NOT BE LIABLE FOR ANY SPECIAL, INDIRECT, INCIDENTAL OR CONSEQUENTIAL DAMAGES OR LOSSES, INCLUDING LOSS OF DATA, ARISING FROM ANY CAUSE OR THEORY.

Since some countries or states do not allow limitation of the term of an implied warranty, or exclusion or limitation of incidental or consequential damages, the limitations and exclusions of this warranty may not apply to every buyer. If any provision of this Warranty is held invalid or unenforceable by a court or other decision-maker of competent jurisdiction, such holding will not affect the validity or enforceability of any other provision.

Fluke Corporation
6920 Seaway Blvd.
Everett, WA 98203
U.S.A.

Fluke Europe B.V
PO Box 1186
5602 BD EINDHOVEN
The Netherlands

Table of Contents

| Title | Page |
|---|------|
| Introduction | 1 |
| Contact Fluke | 1 |
| Safety Information | 2 |
| Specifications | 2 |
| Before You Start | 2 |
| Controls and Display | 2 |
| 2082 Transmitter..... | 4 |
| Transmitter Display | 4 |
| Transmitter Controls and Connections..... | 5 |
| Using the A-Frame to Pinpoint a Fault..... | 6 |
| Preparing a Cable | 6 |
| Connecting the Transmitter | 7 |
| Setting up the Transmitter..... | 8 |
| Pinpointing the Fault with the A-Frame..... | 9 |
| Maintenance | 11 |
| Battery Replacement..... | 11 |
| Accessing the Batteries..... | 11 |
| Product Disposal | 12 |

Introduction

The AF2082 A-Frame cable ground fault locator (the Product) is an optional accessory specifically designed for the Fluke 2082 underground utilities locator. In combination with the Transmitter, the Product will pinpoint the place where a cable metal conductor (either a sheath or a metallic conductor of the wire) touches the ground. The Product can also detect other conductors to ground faults such as pipeline coating defects.

Contact Fluke

Fluke Corporation operates worldwide. For local contact information, go to our website:
www.fluke.com.

To register your product, view, print, or download the latest manual or manual supplement, go to our website.

+1-425-446-5500

fluke-info@fluke.com

Safety Information

General Safety Information is in the printed Safety Information document that ships with the Product and at www.fluke.com. More specific safety information is listed where applicable.

A **Warning** identifies conditions and procedures that are dangerous to the user. A **Caution** identifies conditions and procedures that can cause damage to the Product or the equipment under test.

Specifications

Complete specifications are at www.fluke.com. See the 2082 Product Specifications.

Before You Start

Table 1 is a list of items included with the Product. Use the model numbers to order additional components.

Table 1. Standard Equipment

| Model Number | Description | Part Number |
|--------------|------------------------------------|-------------|
| AF2082 | A-Frame Cable Ground Fault Locator | 6074031 |
| -- | Carrying Case | -- |

Controls and Display

Table 2. Controls

| Item | Description |
|----------|--|
| 1 | Power On/Off : Push for 2 seconds to turn on or turn off the A-Frame. |
| 2 | Speaker Volume : Push repeatedly to loop between mute and three levels of volume. |

Table 3. Display

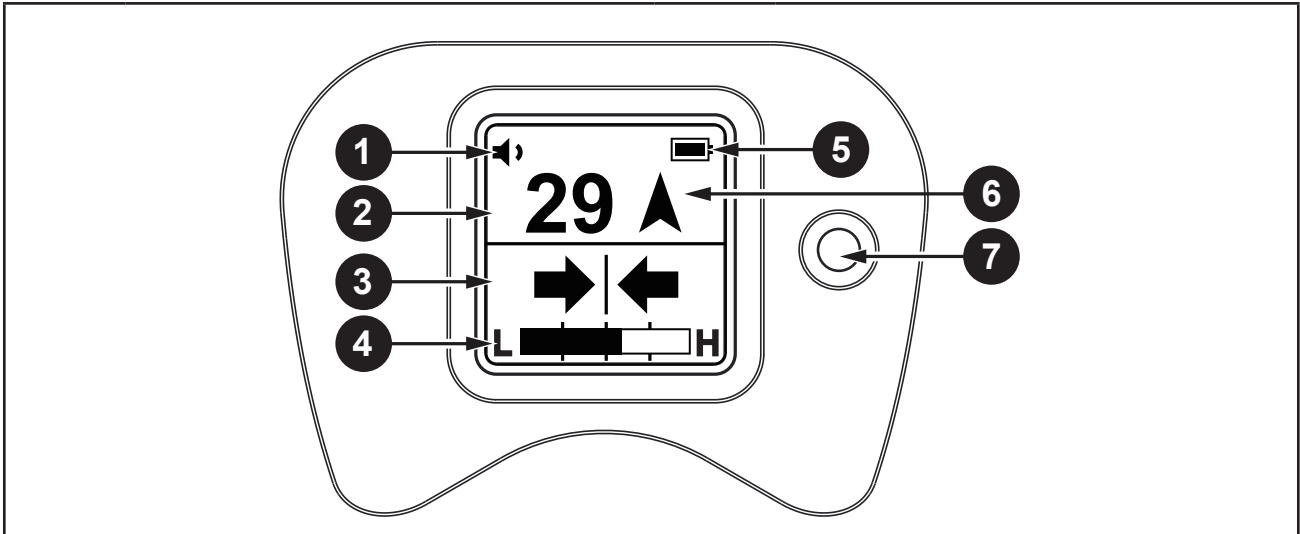

| Item | Description | Item | Description |
|------|-------------------------------------|------|----------------------------|
| 1 | Speaker Volume Setting | 2 | 2-digit Fault Signal Level |
| 3 | Left/Right Cable Position Indicator | 4 | Signal Strength Indicator |
| 5 | Battery Indicator | 6 | Fault Direction Compass |
| 7 | Light Sensor | | |

2082 Transmitter

The Transmitter applies a fault find signal to the utility under test. Use the Transmitter in combination with the A-Frame to receive the signal and pinpoint a place of the fault.

Transmitter Display

The contents of the screen depend on the function being performed. [Table 4](#) shows general functions of the Transmitter screen (for more details, see the *2082 User Manual*).

Table 4. Transmitter Display

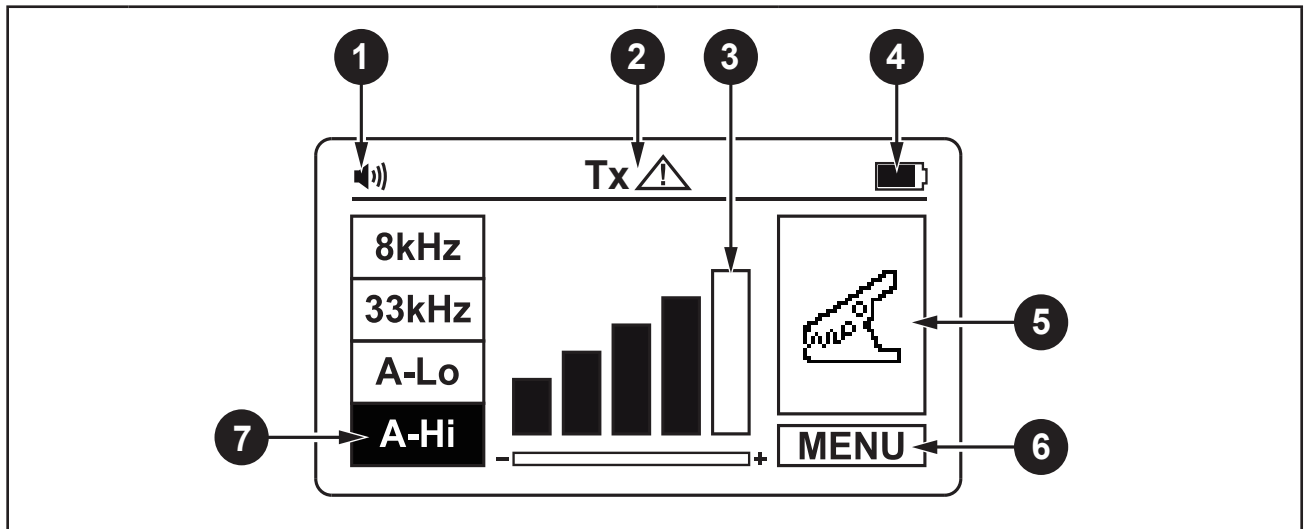

| Item | Description | Item | Description |
|------|---------------------|------|--------------------------------------|
| 1 | Speaker Volume | 2 | Output Hazardous Voltage (over 30 V) |
| 3 | Signal Output Level | 4 | Battery Indicator |
| 5 | Locating Mode | 6 | Menu |
| 7 | Frequency Selection | | |

Transmitter Controls and Connections

Table 5 shows general functions of the Transmitter controls and connections (for more details, see the 2082 User Manual).

Table 5. Transmitter Controls

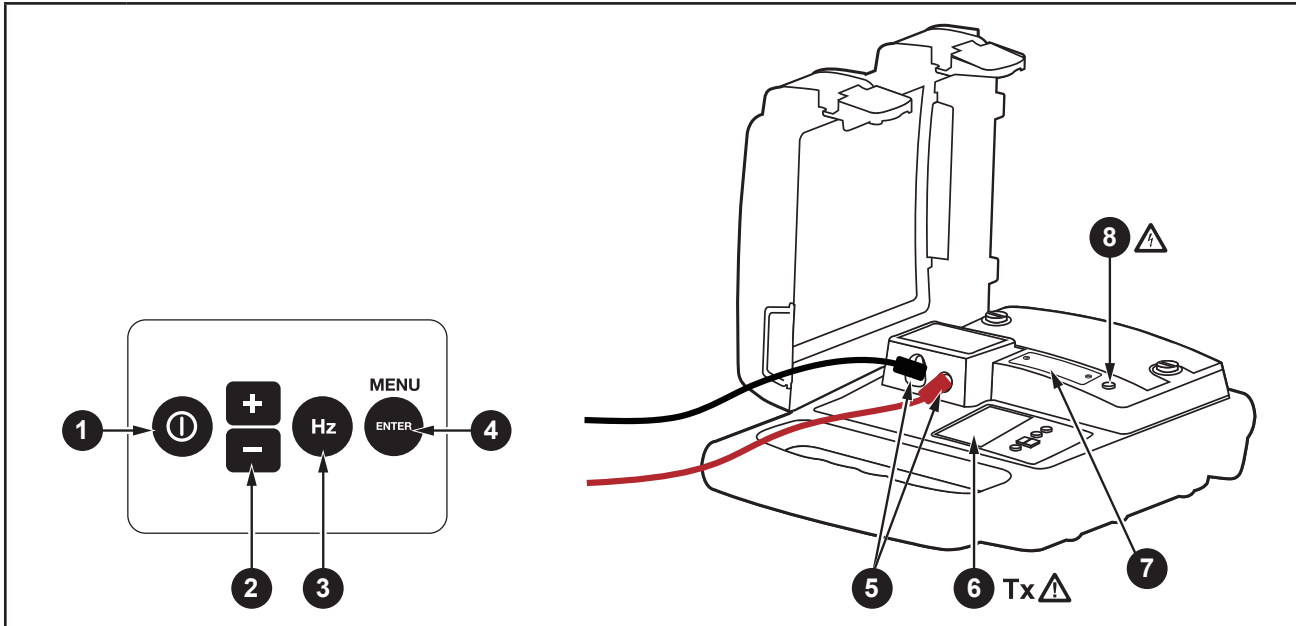

| Item | Description | | | | | | | | |
|---------------|---|-------|-------------------|--------|--------------------|---------------|--------------------------|-------|------------|
| 1 | Power On/Off (ⓘ) : press for 2 seconds to turn the Transmitter ON/OFF. Indication shows up on the screen. | | | | | | | | |
| 2 | Up/Down (+ / - multifunction buttons) : increase or decrease signal strength on main screen, up/down selection of functions in menu screen; Increase/decreases volume and brightness in submenu screens. | | | | | | | | |
| 3 | Frequency selection (Hz) : press momentarily to toggle between available frequency options: <table border="1" data-bbox="258 1365 874 1516"> <tbody> <tr> <td>8 kHz</td> <td>8 kHz Active mode</td> </tr> <tr> <td>33 kHz</td> <td>33 kHz Active mode</td> </tr> <tr> <td>50 Hz / 60 Hz</td> <td>Power mode (50 or 60 Hz)</td> </tr> <tr> <td>Radio</td> <td>Radio mode</td> </tr> </tbody> </table> | 8 kHz | 8 kHz Active mode | 33 kHz | 33 kHz Active mode | 50 Hz / 60 Hz | Power mode (50 or 60 Hz) | Radio | Radio mode |
| 8 kHz | 8 kHz Active mode | | | | | | | | |
| 33 kHz | 33 kHz Active mode | | | | | | | | |
| 50 Hz / 60 Hz | Power mode (50 or 60 Hz) | | | | | | | | |
| Radio | Radio mode | | | | | | | | |
| 4 | ENTER / MENU : Push momentarily to enter Transmitter settings menu. | | | | | | | | |
| 5 | Terminals for direct connection and signal clamp | | | | | | | | |
| 6 | Tx ⚠ Hazardous output voltage indicator. The icon on the screen indicates the transmitter is outputting voltages ≥ 30 V. | | | | | | | | |
| 7 | Protection fuse | | | | | | | | |

| | |
|----------|--|
| 8 | <p>⚠ Hazardous voltage indicator (over 30 V)</p> <p>The red solid light indicates the presence of AC voltage ≥ 30 V on the circuit under direct connection mode.</p> <p>The red blinking light indicates the presence of voltages above 30 V on the Transmitter terminals under A-Lo and A-Hi mode (generated and/or measured). In case of the presence of line voltage >50 V (typical) during the operation of A-Lo or A-Hi mode, the transmitter automatically disables A-Lo and A-Hi modes, the red solid light indicator appears.</p> <p>Always check the presence of voltage on the circuit by additional voltage tester.</p> <p>⚠ Use caution when above voltage indication warnings are ON.</p> |
|----------|--|

Using the A-Frame to Pinpoint a Fault

⚠ Warning

To prevent possible electrical shock, fire, or personal injury, always be aware of the location of buried utilities (especially buried power lines) when pushing the spikes of the A-Frame into the soil.

The spikes of the A-Frame are sharp. Always handle carefully to avoid injury.

The A-Frame is used to detect ground faults on cables and pipes. In the case of cables, faults are usually caused by insulation damage allowing the metallic sheath or internal conductor to become in contact with the ground. In the case of pipes, the faults consist of coating defects.

The A-Frame works in conjunction with the 2082 Transmitter.

Preparing a Cable

1. Disconnect and isolate the cable on both ends. Make sure to disconnect all ground bonding. This will ensure that the test signal traveling through the ground fault is not masked or does not interfere with the one conducted by grounding bonding to the ground. The A-Frame cannot distinguish between these two signals.

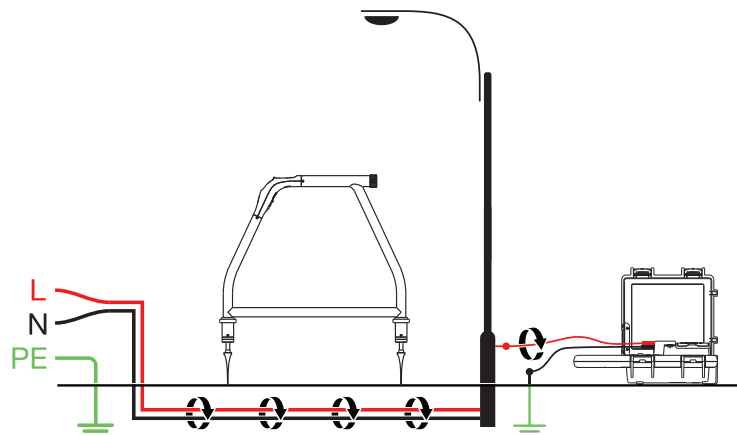

2. Use the resistance measuring function on the Transmitter, or a dedicated resistance measuring device, to identify a cable with a fault to ground. The A-Frame will typically detect faults up to 2 M Ω (depending on the distance from the Transmitter, soil conditions, etc.).

When at A-Lo / A-Hi mode, the  indicator will blink. In case of a voltage presence ≥ 10 V (typical) on the circuit under test, the Ω measurement will be opt out under MENU screen.

3. Optionally, you can precisely detect and mark cable locations using the 2082 receiver. Refer to the *2082 User Manual* for detailed instructions how to locate underground utilities.

Connecting the Transmitter

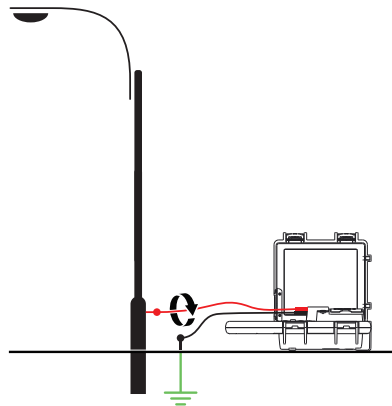

Warnings: Read Before Using

To prevent possible electrical shock, fire, or personal injury:

- Use the 2082 Transmitter only as specified in 2082 User Manual or the protection provided by the instrument may be compromised.
- Check and read all safety information in *2082 User Manual* before use.
- Inspect the test leads before use. Do not use if insulation is damaged or metal is exposed.
- Check the test leads for continuity. Replace damaged test leads before using the Product.
- Never operate the Product with the battery cover removed or the case open.
- Use extreme caution when working around bare conductors or bus bars. Contact with the conductor could result in electric shock.
- Disconnect and isolate the cable on both ends before connecting the Transmitter to the cable.

Setting up the Transmitter

1. Turn on the Transmitter, push power button for 2 seconds.
2. Connect the black and red test leads to the Transmitter inputs. The Transmitter will switch automatically to Direct Connection Mode and the display will show the direct connection icon.
3. Insert the ground stake into the ground a few yards away, perpendicular to the line. Connect the black lead to the ground stake with an alligator clip.
4. Connect a red test lead to the target line.
5. Push Hz button repeatedly to select A-LO (A-Frame low signal) or A-Hi (A-Frame high signal). Use A-LO for higher accuracy pinpointing. Use the A-Hi setting if the line to be surveyed is long or the fault resistance is high.
6. Push the +/- buttons to set the output to level one. Increase the level if the resulting signal strength is poor. Increasing the signal unnecessarily may result in the signal “bleeding off” onto other services and creating misleading “ghost” signals. It will also drain more power from the battery.

Note

When connected, the Transmitter will emit a beep tone. The better the connection to the line and ground, the faster the beep tone will be. Check for a good connection by disconnecting and then reconnecting the red lead. It is also possible to check the signal current being supplied by the Transmitter by entering the user menu and selecting the mA option.

Things that can affect the quality of connection are a rusty pipe connection point (clean the connection area with a wire brush) or poor grounding. To improve the connection quality due to poor grounding, try inserting the stake into damp ground. If necessary, dampen the surrounding ground with water. If grounding is still an issue, try connecting test lead to a manhole cover surround. Avoid connecting to fence railings as these may create return signal currents along the fencing that will interfere with the locating signal.

Note

If the signal level bars do not fill, this indicates that the impedance of the line is limiting the current output. Increasing the output beyond this point will not increase the signal. If more signal is required, check the quality of the connection to the line and ground.

When connecting to large diameter pipes and cables, it is sometimes not possible to find a suitable projection to apply the alligator clip. If the material is ferrous, use a magnet to make contact to the line and then attach the alligator clip to a magnet. For example: making a connection to a street lighting circuit. Usually it is practice to connect the sheath of a lighting cable to the metallic inspection cover of a street lamp. Making a connection to the inspection plate will induce a signal to the cable via the plate and sheath. Usually, there is no projection on the plate on which to clip so using a magnet on the plate provides a suitable clipping point.

Pinpointing the Fault with the A-Frame

1. Remove the rubber spike covers from the A-Frame.
2. Push the **On/Off** button to turn the unit on.
3. Use the Left/Right indicator arrows to position A-Frame over the cable. At that point, the bar graph at the bottom of the display will show maximum value for the test signal strength. The speaker will emit a pulsed tone on one side of the cable and a solid tone on the other, so it is possible to locate the cable without looking at the screen. If necessary, adjust the volume by using short presses on the speaker button  .



Note

If the spikes are not in the ground or there is only a very low signal, the 2-digit Fault Signal Level reading and Fault Direction Compass arrow may not be visible. These are only shown when there is a valid fault find signal.

If the position of the line is different when comparing the Left/Right position to the peak bar graph position, there could be a distorted signal that may affect readings. Proceed with caution.

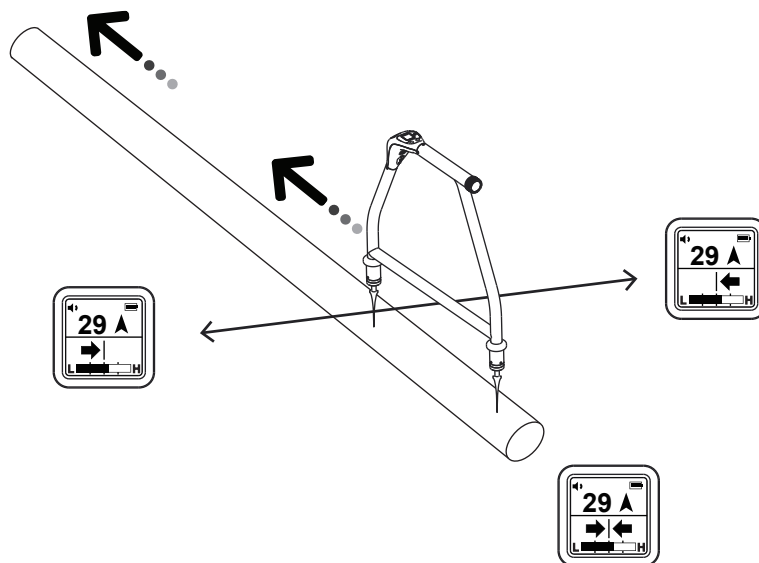

4. Start near the Transmitter. Hold the A-Frame in line with the route of the cable. Walk along the route of the line placing the spikes of the A-Frame in the ground every two or three paces. Allow a couple of seconds for the readings to settle before moving to the next position. Keep the A-Frame aligned with the cable by using the Left/Right arrows.

Note

Initially, the Fault Direction Compass arrow on the display may point towards the Transmitter grounding stake, but as you continue walking along the cable away from the Transmitter it will fluctuate or disappear. The 2-digit Fault Signal Level may also continue decreasing or disappear. This is because the A-Frame detects signals conducted by the Transmitter ground stake and a cable fault is further along the line.

5. In proximity of the fault, the A-Frame will detect the fault signal and the Fault Direction Compass arrow will point forward.
6. Continue moving forward. The 2-digit Fault Signal Level reading will increase as the fault is neared. When you cross the place of the fault, the Compass Fault Detection will change a direction and the 2-digit Fault Signal level will start decreasing as you go away from the fault. Maximum reading will be just before and just after the fault.

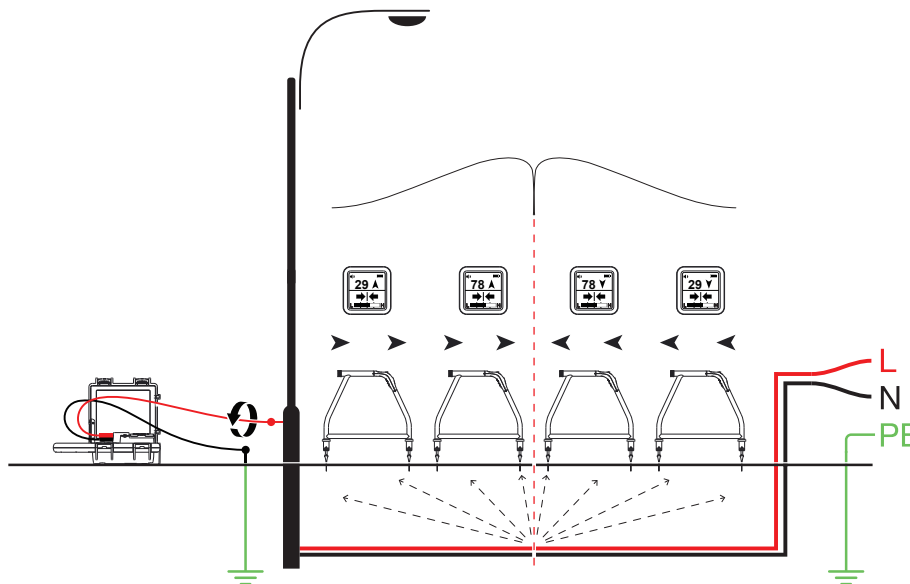

7. Carefully place the A-Frame before and after the fault to pinpoint it. Repeating this in a line perpendicular to the direction of the cable will pinpoint the fault laterally.

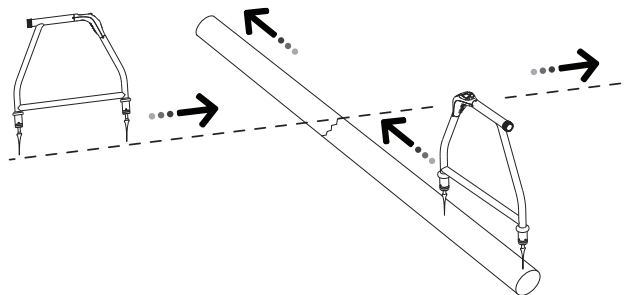

Note

If it is suspected that there is just one fault, insert the A-frame approximately 3 ft (1 m) from the ground stake. Note the two digit number - this is approximately the maximum reading that will be measured over the fault.

Maintenance

Periodically wipe the case with a damp cloth and mild detergent. Do not use abrasives or solvents.

Warnings

To prevent possible electrical shock, fire, or personal injury:

- Repair the Product before use if the battery leaks.
- Have an approved technician repair the Product.
- Use only specified replacement parts.

Battery Replacement

The unit is powered by six AA alkaline batteries (included). When the battery indicator on the screen indicates empty  , the batteries should be replaced.

Warnings

To prevent possible electrical shock, fire, or personal injury:

- Replace all batteries at the same time.
- Do not mix new and old batteries.
- This can lead to batteries being reverse charged and can cause damage, heat and even fire.

Accessing the Batteries

Unscrew the battery cap on the A-Frame handle and remove by gently pulling the battery holder.

When inserting the battery pack, ensure the correct orientation of the holder. The two contacts at the end of the battery pack should be at the bottom as shown in the adjacent graphic.

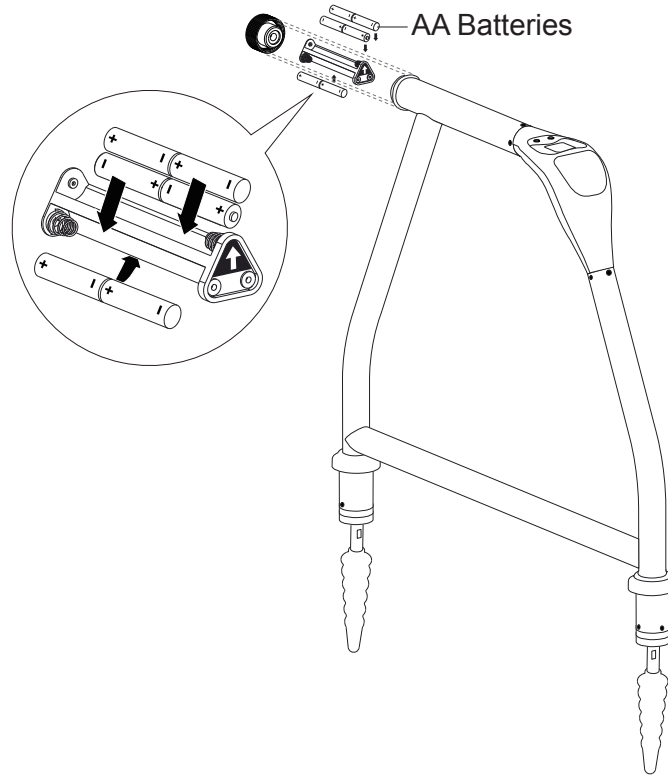

Product Disposal

Dispose of the Product in a professional and environmentally sound manner:

- Delete personal data on the Product before disposal.
- Remove batteries that are not integrated into the electrical system before disposal and dispose of batteries separately.
- If this Product has an integral battery, put the entire Product in the electrical waste.